

INTERNATIONAL JOURNAL OF HIGH-ENERGY PHYSICS

CERN COURIER

VOLUME 50 NUMBER 7 SEPTEMBER 2010



Herschel's eye on the infrared sky

DARESBURY

First breakthrough
for EMMA p7

CANADA

Bright prospects
for TRIUMF p24

BROOKHAVEN

A rare feast of
anniversaries p31



Many instruments. Many people. Working together.

Want to achieve LINAC energy stabilization?

You can control the amplitude and phase of the accelerating field of your machine with Libera LLRF digital RF stabilization system, and couple it with Libera Sync, the low-jitter clock distribution system. Combine it with high resolution position information from Libera Brilliance Single Pass.

These systems are designed to work together to improve beam quality and to reach the performance goals of your machine in a cost-effective way.

Because we know that the machine is more than just the sum of its parts.



Send a request to: sales@i-tech.si

Libera

Covering current developments in high-energy physics and related fields worldwide

CERN Courier is distributed to member-state governments, institutes and laboratories affiliated with CERN, and to their personnel. It is published monthly, except for January and August. The views expressed are not necessarily those of the CERN management.

Editor Christine Sutton
Editorial assistant Carolyn Lee
 CERN, 1211 Geneva 23, Switzerland
E-mail cern.courier@cern.ch
Fax +41 (0) 22 785 0247
Web cerncourier.com

Advisory board Luis Álvarez-Gaumé, James Gillies, Horst Wenninger

Laboratory correspondents:

Argonne National Laboratory (US) Cosmas Zachos
Brookhaven National Laboratory (US) P Yamin
Cornell University (US) D G Cassel
DESY Laboratory (Germany) Ilka Flegel, Ute Wilhelmssen
EMFCSC (Italy) Anna Cavallini
Enrico Fermi Centre (Italy) Guido Piragino
Fermi National Accelerator Laboratory (US) Judy Jackson
Forschungszentrum Jülich (Germany) Markus Buescher
GSI Darmstadt (Germany) I Peter
IHEP, Beijing (China) Tongzhou Xu
IHEP, Serpukhov (Russia) Yu Ryabov
INFN (Italy) Romeo Bassoli
Jefferson Laboratory (US) Steven Corneliussen
JINR Dubna (Russia) B Starchenko
KEK National Laboratory (Japan) Youhei Morita
Lawrence Berkeley Laboratory (US) Spencer Klein
Los Alamos National Laboratory (US) Rajan Gupta
NCSL (US) Ken Kingery
Nikhef (Netherlands) Paul de Jong
Novosibirsk Institute (Russia) S Eidelman
Orsay Laboratory (France) Anne-Marie Lutz
PSI Laboratory (Switzerland) P-R Kettle
Saclay Laboratory (France) Elisabeth Locci
Science and Technology Facilities Council (UK) Peter Barratt
TRIUMF Laboratory (Canada) Marcello Pavan

Produced for CERN by IOP Publishing Ltd
 IOP Publishing Ltd, Dirac House, Temple Back,
 Bristol BS1 6BE, UK
 Tel +44 (0)117 929 7481

Publisher Susan Curtis
Production editor Jesse Karjalainen
Technical illustrator Alison Tovey
Group advertising manager Ed Jost
Recruitment advertisement manager Chris Thomas
Advertisement production Katie Graham
Marketing & Circulation Angela Gage

Head of B2B & Marketing Jo Allen
Art director Andrew Giaquinto

Advertising
 Tel +44 (0)117 930 1026 (for UK/Europe display advertising)
 or +44 (0)117 930 1164 (for recruitment advertising);
 E-mail: sales@cerncourier.com; fax +44 (0)117 930 1178

General distribution Courier Addressage, CERN, 1211 Geneva 23,
 Switzerland. E-mail: courier-addressage@cern.ch
 In certain countries, to request copies or to make address changes,
 contact:

China Keqing Ma, Library, Institute of High Energy Physics,
 PO Box 918, Beijing 100049, People's Republic of China.
 E-mail: keqingma@mail.ihep.ac.cn
Germany Veronika Werschner, DESY, Notkestr. 85, 22607 Hamburg,
 Germany. E-mail: desypr@desy.de
Italy Loredana Rum or Anna Pennacchiotti, INFN, Casella Postale
 56, 00044 Frascati, Rome, Italy. E-mail: loredana.rum@inf.infn.it
UK Mark Wells, Science and Technology Facilities Council, Polaris
 House, North Star Avenue, Swindon, Wiltshire SN2 1SZ.
 E-mail: mark.wells@stfc.ac.uk
US/Canada Published by Cern Courier, 6N246 Willow Drive,
 St Charles, IL 60175, US. Periodical postage paid in St Charles, IL,
 US. Fax 630 377 1569. E-mail: creative_mailing@att.net
 POSTMASTER: send address changes to: Creative Mailing Services,
 PO Box 1147, St Charles, IL 60174, US

Published by European Organization for Nuclear Research, CERN,
 1211 Geneva 23, Switzerland. Tel +41 (0) 22 767 61 11
 Telefax +41 (0) 22 767 65 55

Printed by Warners (Midlands) plc, Bourne, Lincolnshire, UK

© 2010 CERN ISSN 0304-288X

CERN COURIER

VOLUME 50 NUMBER 7 SEPTEMBER 2010



Who needs computers? p12



A bright future for TRIUMF p24



Smiles all round for Evans p33

News

5

LHC results top the bill in Paris. IUPAP working group organizes two-day international symposium on plans for worldwide nuclear physics. Electrons signal a world first for EMMA. Copernicium enters the periodic table. Multibunch injection provides a quick fill. TOTEM sees elastic scattering and LHCf completes first run.

Sciencewatch

10

Astrowatch

11

CERN Courier Archive

12

Features

IPAC '10: accelerating to an international level

15

A report on the first of the new international series of annual accelerator conferences.

Europe charts future for radioactive beams

21

The EURORIB '10 conference looked forward to an exciting time with radioactive ion beams.

Canada's bright future in subatomic physics

24

Assured funding and a new facility provide opportunities for TRIUMF.

The subtle side of superconductivity

27

A look at the devious nature of the fault that brought the LHC to a standstill.

Faces and Places

31

Recruitment

38

Bookshelf

43

Inside Story

46

Cover: This artist's impression depicts the Herschel spacecraft, with its 3.5-m mirror, against a backdrop of the spacecraft's image of the Rosette molecular cloud. The colours correspond to different temperatures of dust, from 10 K in red to 40 K in blue. The observations of the molecular cloud were made with Herschel's Photoconductor Array Camera and Spectrometer and the Spectral and Photometric Imaging Receiver – two instruments whose first results have been published in a special issue of *Astronomy & Astrophysics* (p11). (Courtesy ESA/PACS, SPIRE & Consortia/F Motte.)

IOP Publishing



COMSOL CONFERENCE PARIS



invitation

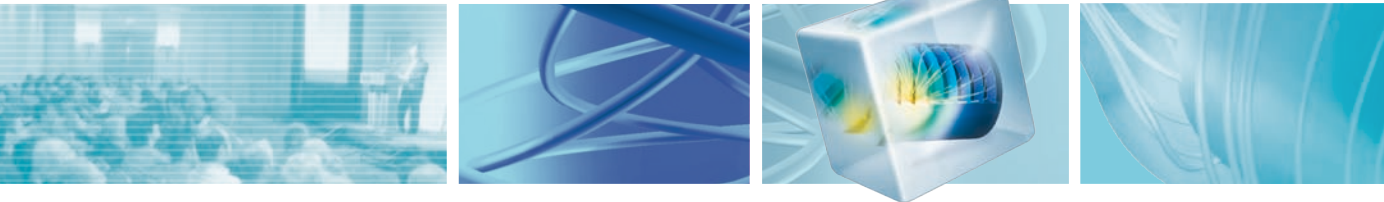

Join the Leaders in Multiphysics Simulation
at the COMSOL Conference 2010

PARIS, NOVEMBER 17-19

Minicourses

Get training in more than a dozen specialized minicourses

User Presentations

Over a hundred presentations from users of COMSOL

Exhibition & Poster Session

Showcase of simulation products and services

Demo Stations

Test drive new products and meet with support engineers

Awards Banquet

Prizes for best papers and posters

GOLD SPONSORS



Microsoft

MEDIA SPONSORS



Design World



physicsworld.com



comsol.eu/conference2010

© 2010 COMSOL, Inc. COMSOL and COMSOL Multiphysics are registered trademarks of COMSOL AB.
Other product or brand names are trademarks or registered trademarks of their respective holders.



ICHEP 2010

LHC results top the bill in Paris

More than 1100 physicists gathered in the Palais des Congrès conference centre in Paris on 22–28 July to attend the 35th International Conference on High Energy Physics (ICHEP), the world's largest conference on particle physics. As the first meeting in the series to announce results from the LHC, it caught the attention not only of physicists but also of media around the world and the president of the host country, France.

President Nicolas Sarkozy, addressed the conference on 26 July, at the official opening of the plenary sessions. In a spirited speech, he exhorted the particle-physics community to continue its quest to understand the nature of the universe, and stated his belief that investment in fundamental research is critical for the progress of mankind.

News from the LHC experiments had already reached the physicists during the three days of parallel sessions with which the ICHEP meetings traditionally begin. One of the items of breaking news from the ATLAS and CMS experiments was the first observation of top quark candidates at the LHC. The top, the heaviest elementary particle observed to date, has so far been produced only at Fermilab's Tevatron collider in the US.

Another hotly anticipated presentation at ICHEP concerned the CDF and DØ experiments at the Tevatron. The two experiments have not yet spotted the Higgs boson but have further limited the territory in which it may be hiding. So, the Higgs is still out there waiting to be found, and the LHC experiments have shown at ICHEP that they are well on the way to joining the hunt.

With their first measurements the LHC experiments are rediscovering the particles that lie at the heart of the Standard Model – an essential step before moving on to



At the press conference on 26 July, from left to right: Guy Wormser, chair of the local organization committee of the ICHEP conference and director of the Laboratoire de l'Accélérateur Linéaire, Orsay; Rolf Heuer, director-general of CERN; Mel Shochet of the University of Chicago, chair of the US High-Energy Physics Advisory Panel; Atsuto Suzuki, director-general of KEK and chair of the International Committee for Future Accelerators. (Photos courtesy T Pritchard.)

make discoveries. The quality of the results presented at ICHEP bears witness both to the excellent performance of the LHC and to the high quality of the data in the experiments. The LHC, which is still in its early days, is making steady progress towards its ultimate operating conditions. By the time of the conference, the luminosity had already risen by a factor of more than a thousand since the end of March – and has since risen further still (p8).

The rapid progress with commissioning the LHC beam has been matched by the speed with which the data on billions of collisions have been processed by the Worldwide LHC Computing Grid. This allows data from the experiments to be analysed at collaborating centres around the world, resulting in a truly international experience.

- A feature-length report on ICHEP 2010 will



President Sarkozy opened the conference.

appear in a future edition of the *CERN Courier*. For details on all of the talks, see www.ichep2010.fr.

Sommaire

Les résultats du LHC en tête d'affiche à Paris	5	Une injection multipaquets pour des remplissages plus rapides	8
Physique nucléaire : l'IUPAP organise un symposium international sur les projets menés dans le monde	6	TOTEM observe la diffusion élastique et LHCf boucle sa première période d'exploitation	8
Première mondiale pour EMMA et son faisceau d'électrons	7	Les étudiants : un comportement humain peu représentatif	10
Le copernicium fait son entrée dans le tableau périodique	7	L'observatoire Herschel livre ses premiers résultats	11

NUCLEAR PHYSICS

IUPAP working group organizes two-day international symposium on plans for worldwide nuclear physics

A two-day Symposium on Nuclear Physics and Nuclear Physics Facilities, held at TRIUMF on 2–3 July, provided the opportunity for proponents of nuclear science across the world to learn about and discuss present and future plans for research in nuclear physics, as well as the upgraded and new research facilities that will be required to realize these plans.

The Working Group on International Cooperation in Nuclear Physics (WG.9) of the International Union of Pure and Applied Physics (IUPAP) organized the symposium. It was held as a response to the mandate given to the group by the OECD Global Science Forum in a missive from its chair, Hermann-Friedrich Wagner, following the recent report of the OECD Global Science Forum Working Group on Nuclear Physics. Three half-day presentations were arranged by the US Nuclear Science Advisory Committee (NSAC), by the Nuclear Physics European Collaboration Committee (NuPECC) and by the Asian Nuclear Physics Association (ANPhA), which was formed about two years ago on the urging of IUPAP WG.9.

The presentations at the symposium focused on five main themes of nuclear physics today: “Can the structure and interactions of hadrons be understood in terms of QCD?”, “What is the structure of nuclear matter?”, “What are the phases of nuclear matter?”, “What is the role of nuclei in shaping the evolution of the universe, with the known forms of matter comprising only a meagre 5%?” and “What is the physics beyond the Standard Model?”

The presentations led to extensive discussions among the various representatives. On the final half day, after a synopsis of the presentations and discussions by Robert Tribble of Texas A&M University, a panel discussion took place between the three nuclear-physics groupings of NSAC, NuPECC and ANPhA. This was followed by a series of statements by science administrators from the US Department of Energy, the Office of Science Nuclear Physics, the National Science Foundation Nuclear Physics, the INFN Third Commission, the

French research bodies IN2P3/CNRS and the CEA/Service de Physique Nucleaire, the Japan Ministry of Education, Science, and Technology, the Korea Research Council and the China Institute of Atomic Energy.

For the first time, the symposium brought together nuclear-physics researchers, laboratory directors and nuclear-science administrators in an international setting. It showed a vigorous field of nuclear physics with demanding forefront challenges and large nuclear physics facilities being upgraded or coming on line presently or in the near future: CEBAF 12 GeV at Jefferson Laboratory, FRIB at Michigan State University, SPIRAL2 at GANIL, ISAC at TRIUMF, RIBF at RIKEN Nishina Center, J-PARC, FAIR at GSI, the upgraded RHIC at

Brookhaven and in the more distant future EIC at Brookhaven or Jefferson Lab, ENC at FAIR, EURISOL (p19) and LHeC at CERN. There are also several nuclear-physics facilities planned for China and Korea.

IUPAP WG.9 has given great encouragement to efforts aimed at strengthening co-operation in regional and international nuclear physics. At the symposium the nuclear-physics community was informed of the formation of a Latin America Nuclear Physics Association (ALAFNA) to strengthen nuclear physics in Latin America. Similar attempts may be undertaken in Africa.

● For further details about the working group, see the WG.9 website at www.iupap.org/wg/icnp.html.

Take a *Clearer* look at Kurt J. Lesker Process Equipment Division



When you do, you'll see that KJLC offers quality vacuum deposition equipment, assemblies and accessories for your process. Contact us today!

Kurt J. Lesker
Company

www.lesker.com

Kurt J. Lesker Company Ltd.
Europe
+44 (0) 1424 458100
saleseu@lesker.com

Kurt J. Lesker Canada Inc.
Canada
416.588.2610
800.465.2476
salescan@lesker.com

Kurt J. Lesker Company
United States
412.387.9200
800.245.1656
salesus@lesker.com

Kurt Lesker (Shanghai) Trading Company
科特·莱思科(上海)商贸有限公司
Asia
+86 21 62181240
saleschina@lesker.com



10-133

ACCELERATORS

Electrons signal a world first for EMMA

On Tuesday 22 June at 10.37 p.m. an electron beam passed for the first time through four sectors of EMMA, the prototype that has been built at the UK's Daresbury Laboratory to test the concept of the nonscaling fixed-field alternating gradient accelerator (FFAG). As the beam passed more than half way round the accelerator's circumference it marked a world "first" and demonstrated the underlying soundness of the most technically demanding aspects of the design.

FFAGs have a ring of magnets to focus the beam strongly, as in an alternating-gradient synchrotron, but the fixed magnetic field means that the beam spirals outwards as it is accelerated, as in a cyclotron. The result is more compact than a cyclotron, however, and although the concept is some 50 years old such machines are now being considered world-wide for a variety of applications (*CERN Courier* September 2008 p21). EMMA, the Electron Model for Many Applications, is a 20 MeV accelerator, which will test for the first time the concept of the nonscaling FFAG, in which the betatron tunes (the frequency of the transverse oscillations) are allowed to vary during the acceleration process. Nonscaling FFAGs are attractive because they tend to have much smaller transverse apertures than scaling FFAGs (where the beam optics remain

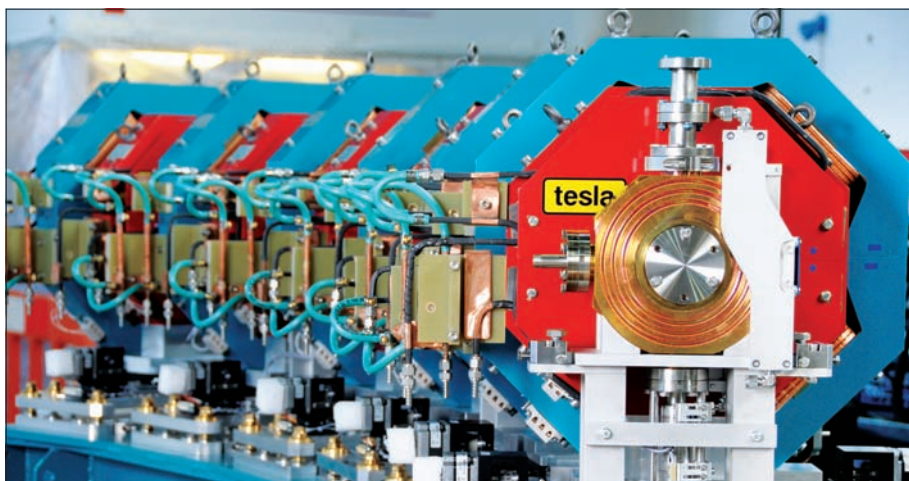

EMMA, the world's first nonscaling FFAG, is based on 84 quadrupole magnets. (Courtesy STFC.)

constant during acceleration), which were first demonstrated at KEK in 2000 (*CERN Courier* October 2000 p11).

EMMA has been built at the Daresbury Laboratory of the Science and Technology Facilities Council, under the auspices of the project for the CONstruction of a Nonscaling FFAG for Oncology, Research and Medicine (CONFORM). The electron beam injected into EMMA is generated by another novel accelerator system at Daresbury, the Accelerators and Lasers in Combined

Experiments (ALICE). ALICE is the first accelerator in Europe to operate using energy recovery, where the energy used to create its high-energy beam is captured and reused after each circuit of the accelerator for further acceleration of fresh particles (*CERN Courier* January/February 2009 p7).

The next steps for EMMA, which are now underway, are to complete commissioning of the full ring, followed by the world's first demonstration of the new acceleration technique.

ELEMENTS

Copernicium enters the periodic table

On 12 July, a ceremony at GSI celebrated the entry of copernicium into the periodic table of elements with a symbolic christening for the new element. Copernicium is 277 times heavier than hydrogen and the heaviest element officially recognized in the periodic table. It is named in honour of the astronomer Nicolaus Copernicus.

Element 112 was discovered at GSI in 1996 by an international team of scientists led by Sigurd Hofmann. The element has

officially carried the name copernicium and the symbol Cn since 19 February 2010. Naming the element after Copernicus follows the long-standing tradition of choosing an accomplished scientist as eponym.

The team of scientists at GSI, from Germany, Finland, Russia and Slovakia, produced the new element for the first time in February 1996, by firing zinc ions onto a lead foil. The fusion of the nuclei of the two elements produced one atom of element 112. Although it is stable for only a fraction of a second, the team identified the new element through the radiation emitted during its decay. Further independent experiments at other research facilities confirmed the discovery of element 112 and in 2009 the International Union of Pure and Applied Chemistry officially recognized the existence



Sigurd Hofmann, head of the international team that discovered element 112, shakes hands with Roland Koch, minister president of Hesse (centre), as Eva Kühne-Hörmann, Hessian minister for science and arts, looks on amid the confetti "emitted" by the element at its christening.

of element 112 and acknowledged the GSI team's discovery by inviting them to propose a name.

LHC NEWS

Multibunch injection provides a quick fill

Beam commissioning at the LHC continues to result in increasing luminosity for the experiments. The end of the first week of August saw data-taking pass another milestone, with integrated luminosity reaching 1 pb^{-1} – that is, a thousandfold increase since the end of June.

A major factor has been the implementation of multibunch injection from the Super Proton Synchrotron (SPS). This involves sending several bunches to the LHC in one SPS cycle,

thus reducing the time needed to fill the collider. In tests on 27 July, using this scheme for the first time, the operators sent four bunches at a time into the LHC to give a total of 25 bunches (including one pilot bunch) in each direction.

Then, from around midnight on 30 July, the machine ran with stable beams of 25 bunches, providing 16 colliding pairs per experiment and delivering a peak instantaneous luminosity of around

$2.6 \times 10^{30} \text{ cm}^{-2} \text{ s}^{-1}$. This corresponds to a total stored beam energy of 1.2 MJ. Further long fills with 25 bunches per beam followed in the first week of August, with peak luminosities of up to $3 \times 10^{30} \text{ cm}^{-2} \text{ s}^{-1}$ providing up to 120 nb^{-1} integrated luminosity per fill. By Friday 6 August, with the milestone of 1 pb^{-1} on the horizon, there was a small and well deserved celebration in the CERN Control Room, for the operations and commissioning teams whose hard work makes this progress possible.

TOTEM sees elastic scattering and LHCf completes first run

While the large experiments at the LHC have been collecting the first inverse picobarn of integrated luminosity at 7 TeV in the centre of mass, the two smaller experiments installed at the collider have also passed milestones.

TOTEM, which stands for TOTal cross-section, Elastic scattering and diffraction dissociation Measurement at the LHC, is designed to measure elastic scattering over a range of momentum transfer, as well as a variety of diffractive processes (*CERN Courier* September 2009 p19). To make these observations, the experiment needs to detect particles at angles of less than 1 mrad relative to the beam line, so TOTEM includes detectors in Roman Pots at a distance of 220 m on either side of the CMS collision point (Point 5). The Roman Pots can move in close to the beam line, so the collaboration has to work closely with the LHC collimation experts. Now they have succeeded in moving the detectors close to the beam, locating it with very high precision, first at the beam energy at injection of 450 GeV, and then at the normal running energy of 3.5 TeV per beam. This led to TOTEM's sighting of not only the first candidates for proton–proton elastic scattering at 7 TeV, but also the first candidate for the diffractive process of double-Pomeron-

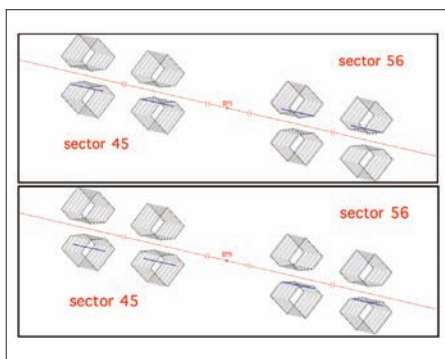

One of the first elastic event candidates recorded by the TOTEM experiment (top), with a candidate for double Pomeron-exchange below. The proton tracks are reconstructed in the detectors in Roman Pots on either side of the intersection point IP5 (not to scale).

exchange – the first time that such an interaction has been seen at 7 TeV.

LHCf, which stands for “LHC forward”, meanwhile, has already completed its first run at the LHC. This experiment consists of two independent detectors located at 140 m either side of the ATLAS collision point (Point 1). It studies the secondary particles created during the head-on collisions in the LHC, the goal being to compare the various

models that are used to estimate the primary energy of ultrahigh-energy cosmic rays from the showers of particles that the primaries create in the atmosphere. LHCf was designed to work with high-energy particles, but at a low luminosity, and the experiment has now collected sufficient data to complete the first phase of the research programme at 450 GeV and 3.5 TeV per beam. The results of the data analysis at 450 GeV will be available by the end of the year, while data at 3.5 TeV will be analysed in 2011. The UA7 experiment carried out at the SPS proton–antiproton collider in the 1980s has already provided information for collisions at beam energies of 450 GeV. LHCf will be the first to provide results at 3.5 TeV and beyond

The detectors used for this first run were removed during a short technical stop of the LHC at the end of July. These were mainly plastic scintillators. The collaboration will now work on replacing them with more radiation-resistant crystal scintillators, to be ready by 2013 when the LHC will run at 7 TeV per beam. The collaboration also plans to change the position of the silicon detectors to improve the performance of the experiment in measuring the energy of the interacting particles.

Les physiciens des particules du monde entier sont invités à apporter leurs contributions aux *CERN Courier*, en français ou en anglais. Les articles retenus seront publiés dans la langue d'origine. Si vous souhaitez proposer un article, faites part de vos suggestions à la rédaction à l'adresse cern.courier@cern.ch.

CERN Courier welcomes contributions from the international particle-physics community. These can be written in English or French, and will be published in the same language. If you have a suggestion for an article, please send your proposal to the editor at cern.courier@cern.ch.

FRIALIT®-DEGUSSIT® Oxide Ceramics

High-quality products made of materials like aluminium oxide and zirconium oxide as well as silicon carbide and silicon nitride with brilliant material properties for extreme requirements in the fields of electrical, high temperature and mechanical engineering and surface finishing.



High voltage accelerator assembly, Ø 400 [16] x L 600 [24]

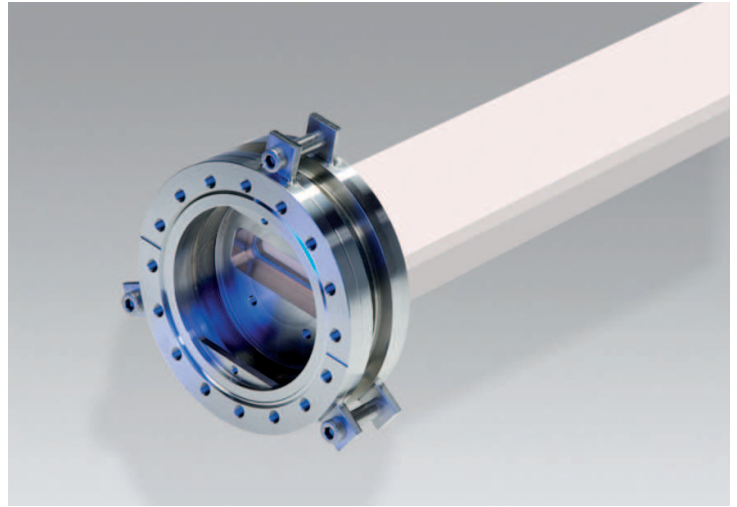

Insulation tube (kicker) for accelerator applications, Ø 180 [7] x L 850 [34]



X-ray source for radiology, Ø 130 [5]

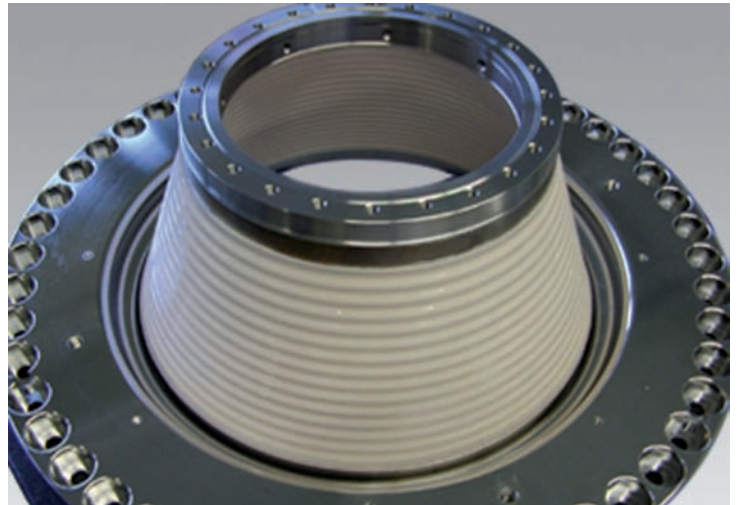

Ceramic-to-metal assembly for research applications, Ø 500 [20]

FRIATEC Aktiengesellschaft

Germany

Tel +49 621 486 1378
Fax +49 621 4 77 999
roger.weber@friatec.de
www.friatec.de

Glynwed AB

Sweden

Tel +46 844 66910
Fax +46 844 66911
cornelia.f.sundberg@glynwed-se.com
www.glynwed-se.com

FRIATEC N.A. LLC

USA

Tel +1 727 753 0880
Fax +1 727 753 0886
jkelly@friatecna.net
www.friatecna.net

Glynwed A/S

Denmark

Tel +45 46 77 25 83
Fax +45 46 75 54 30
pia.kjelstrom@glynwed.dk
www.glynwed.dk

FRIATEC DPL S.A.

France

Tel +33 1 6445 2362
Fax +33 1 6445 2360
pascal.parmentier@glynwed.fr
www.glynwed.fr

Glynwed Russia

Tel +7 495 748 0485
Fax +7 495 748 5339
inna.shuvalova@glynwed.ru
www.glynwed.ru



an *Aliaxis* company

Compiled by John Swain, Northeastern University

Students are poor examples of human behaviour

Most psychological experiments base their conclusions on samples of what are termed “WEIRD” people – that is, people from Western, educated, industrialized, rich, democratic cultures. However, anthropologist Joseph Henrich and psychologists Steven Heine and Ara Norenzayan of the University of British Columbia in Canada have shown that WEIRD people are not at all representative of humanity at large.

Perhaps the most striking example the researchers give concerns the famous Müller-Lyer illusion in which two line segments of equal length with arrow-like ends pointing towards or away from their centres are shown to subjects who are asked if one line looks longer than the other. While WEIRD people tend to see significant differences in the line lengths, most other cultures are taken in to much lesser degrees, and the San people of the Kalahari in southern Africa seem essentially immune. As the paper says in its closing words: “The sample of contemporary Western undergraduates that so overwhelms our database is not just an



The Müller-Lyer illusion. Both lengths are the same.



Western undergraduates are not typical humans. (Courtesy Joe Gough/Dreamstime.)

extraordinarily restricted sample of humanity; it is frequently a distinct outlier *vis à vis* other global samples. It may represent the worst population on which to base our understanding of *Homo sapiens*.”

Further reading

J Henrich *et al.* 2010 *Behavioural and Brain Sciences* **33** 61.

Thinking and speaking together

What really goes on when two people communicate? Greg Stephens of Princeton University and colleagues have used functional MRI to monitor the brain activity of both a speaker and a listener.

They find that when real communication takes place, the listener’s brain is, on average, spatially and temporally correlated with that

of the speaker, the one mirroring the other with a delay. They also find an anticipatory component in the listener’s brain that predicts what will be coming next in the speaker. This effect appears to be stronger the greater the degree of understanding of the listener.

Fans of *Star Trek* will be amused to find that perhaps humans do have their own version of the “Vulcan mind meld” but via speech alone.

Further reading

Greg J Stephens *et al.* 2010 *PNAS Early Edition* doi/10.1073/pnas.1008662107.

The remarkable shrinking proton

The usual measure of the size of a proton is its charge radius, which can be determined from spectroscopy of the hydrogen atom, using the Lamb shift and the fact that s

and p waves behave differently near the origin. Now, Randolph Pohl of the Max Planck Institute for Quantum Optics in Garching and colleagues have used pulsed-laser spectroscopy to perform the analogous measurement for muonic hydrogen, where a negative muon takes the place of the usual electron.

The result is a proton radius that is 10 times

The orbital angular momentum of light

In addition to the spin angular momentum carried by its photons, a beam of light can also have orbital angular momentum if the electric field varies inside the beam. Roughly speaking, a beam with non-zero orbital angular momentum has a sort of twist in the electric field within a wavefront.

While significant effort has gone into thinking about what kind of torques such beams might exert, there has been little attention paid to what diffraction patterns they produce. This has changed with a simple and beautiful result from Jandir Hickmann of the Universidade Federal de Alagoas in Brazil and colleagues.

They have shown that the diffraction pattern from a triangular aperture shows a set of bright spots that can be counted to give the orbital angular momentum in the beam. This is also probably the simplest way to measure this quantity, and an extremely simple one at that.

Further reading

J M Hickmann *et al.* 2010 *Phys. Rev. Letts.* **105** 053904.

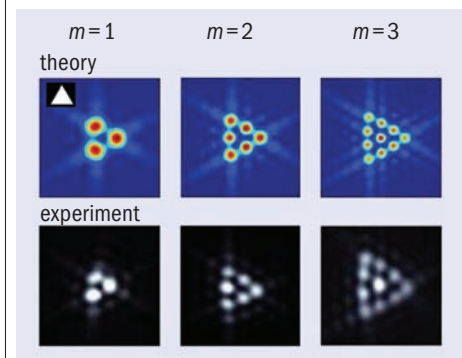

Diffraction patterns for light with orbital angular momentum m passing through a triangular hole.

more precise than the current world average (mainly obtained from ordinary hydrogen) – but, surprisingly, five standard deviations smaller. It is now a challenge to theorists to explain this result and to experimentalists to see if some error has been made.

Further reading

R Pohl *et al.* 2010 *Nature* **466** 213.

Herschel delivers first results

The first scientific results obtained by the Herschel infrared observatory have been published in a special issue of the journal *Astronomy & Astrophysics*. Based on data collected during the first few months of operation, the papers cover a range of sources, from planets through newly-forming stars in our Galaxy to distant galaxies.

The Herschel spacecraft was launched together with Planck by an Ariane 5 rocket on 14 May 2009. Both Herschel and Planck have been put into peculiar orbits round the second Lagrange point of the Sun–Earth system located 1.5 million km from Earth, on Earth’s night side. While Planck spins, slowly scanning the whole sky to map the cosmic microwave background with higher sensitivity and resolution than the Wilkinson Microwave Anisotropy Probe, Herschel performs pointed observations in the far-infrared to submillimetre range. The light collected by the 3.5 m mirror – the largest ever sent into space – can be directed towards three instruments on the focal plan, which is cooled to 2 K by superfluid helium. The temperature of the instruments’ detectors is further reduced to 300 mK by a complex system of cryo-coolers. The cooling is crucial to avoid the heat radiation of the instruments interfering with the observations, but it limits the lifetime of the mission to only 3.5–4 years.

The 152 new publications demonstrate the good performance of this challenging mission. They are all based on observations

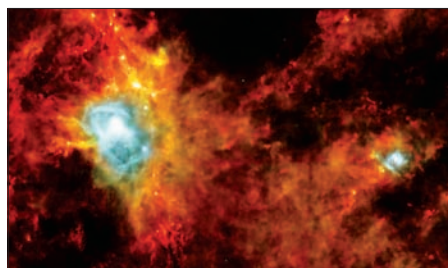

A Herschel image of an area in the stellar nursery of the constellation of Aquila. (Courtesy ESA/ SPIRE & PACS/P André.)

of two of the three instruments because the measurements with the Heterodyne Instrument for the Far Infrared started only in February 2010 owing to a technical problem. The two other instruments have excellent imaging capabilities in different wavebands. The longer the wavelength, the cooler the temperature, which allows Herschel to map the temperature of cold gas and dust structures in the interstellar medium. Prime targets are star-forming regions where large clouds of cold gas and dust slowly collapse to form protostars, which mature into stars within a few million years. The detection by Herschel of new populations of young stars and protostars is one of the highlights and is a key to a better understanding of the processes that lead to the birth of stars. In particular, the detection of high-mass protostars at the edge of regions of ionised hydrogen seems to confirm a complex

formation scenario first proposed in 1977.

Looking at more distant targets, away from the Milky Way, Herschel can probe the evolution of star-forming galaxies over several thousand million years of cosmic history. A “must” for the early mission was to look at two prime fields already extensively observed by space telescopes such as Spitzer in the infrared, Hubble in the visible and Chandra in X-rays. Herschel opens a new wavelength window in these Great Observatories Origins Deep Survey (GOODS) fields, which have been carefully selected to study galaxies out to very high redshift. Its highly sensitive observations have pinpointed about half of the galaxies contributing to the cosmic infrared background. Herschel further finds that the main contribution to this diffuse emission comes from faint galaxies at relatively low redshift ($z < 1$). In the future, by probing the contribution at different redshifts, Herschel will allow researchers to deduce the cosmic history of star formation in the universe.

A call for open time observations with Herschel closed on 22 July and resulted in 585 proposals requesting about 900 days of continuous observing time. There is thus much more science to come from Herschel. The batch of first papers is just the proverbial tip of the iceberg, as the project scientist Göran Pilbratt points out.

Further reading

Astronomy & Astrophysics 2010 **518**.

Picture of the month

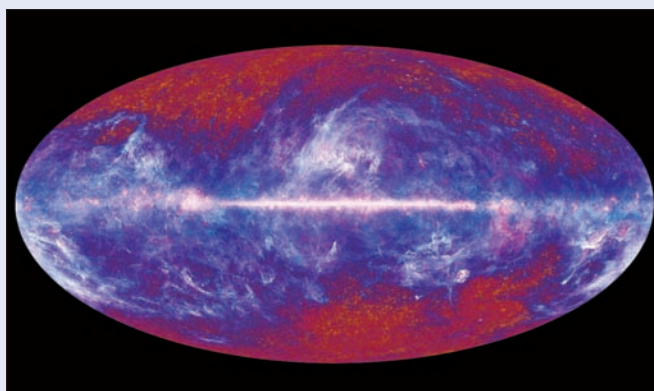

ESA’s Planck mission has finished its first survey of the full sky, producing a splendid 360° view across the “landscape” of the universe. The horizontal plane of the Milky Way galaxy is analogous to surrounding corn fields, with foreground branches and leaves equivalent to the turbulent bluish filaments of cold dust (*CERN Courier* May 2010 p9). The Magellanic Clouds are like nearby villages and the Andromeda galaxy, a bigger city behind. Distant quasars appear as white dots against the red-orange background, akin to distant snow-covered mountains on a sunset sky. Our view of the landscape around us is limited in distance by the atmospheric diffusion of sunlight, while Planck’s microwave view is limited in time by the diffusion of primordial radiation by free electrons, only 380 000 years after the Big Bang. (Courtesy ESA/ LFI & HFI Consortia.)

CERN COURIER ARCHIVE: 1967

A look back to *CERN Courier* vol. 7, September 1967, compiled by Peggie Rimmer

CERN

Computers and computing

The work of CERN is a very small and specialized part of contemporary life but subnuclear physics research could not have sustained its rate of progress had it not been for the parallel development of computers.

The designers of the early computers assumed that programming would be done by small groups of specialists, probably mathematicians, and that it would be undesirable to make the task too easy. For example, von Neumann and Goldstine, who in 1946 proposed what is essentially the modern computer, argued against built-in floating-point arithmetic: "The floating binary point represents an effort to render a thorough mathematical understanding of at least part of the problem unnecessary, and we feel that this is a step in a doubtful direction."

The first successful use of electronic computing to analyse data from a particle-physics experiment was made in 1956 by a group at Berkeley, using a cloud chamber in a beam from the Bevatron.

CERN's first electronic computer began operation in autumn 1958, a Ferranti Mercury; it taught CERN two lessons. Firstly, installing new, large computers brings serious unforeseen difficulties: late delivery and an initial period of recurring hardware and software problems. Secondly, the ready availability of a computer stimulates computer use at an alarming rate; Mercury had barely completed its first year of operation when CERN had to order its second computer, an IBM 709.

With Mercury and the 709 operating together, CERN had its first experience of compatibility problems. This is a continuing source of difficulty as more and more different computers are coming into operation at CERN and many of CERN's programs are used on different computers in Member States.

Fortran made its debut at CERN with the IBM 709, and the use of this language was encouraged so that today it is essentially the only language in general use.

In 1960, the first ideas for flying spot digitizers to measure bubble-chamber film



Left: The IBM 7090 replaced the 709 model in 1963. Right: Human computer William Klein in action.



began to take shape. The prototype device was operating on-line to the IBM 709 in 1962, beginning the trend towards on-line use of computers for processing experimental data. It also had the less enviable distinction of being our first experience of another hard fact of life, namely that adequate software is as essential as hardware – and much more difficult to achieve.

Before being given to the Institute of Mining and Metallurgy at Krakow University in 1966, the Mercury was connected, via a one-kilometre data-link, to counter and spark-chamber equipment in the synchrotron experimental hall, becoming the first computer used on-line at CERN to analyse experimental data in "real-time".

About 10 small computers are now being used for data-acquisition in electronics experiments in the synchrotron experimental halls. If small computers continue to become simultaneously faster and cheaper, the use of a big computer may become the exception rather than the rule.

In any one week, about 400 scientists and engineers use the CERN central computers. In the next five years, this figure may increase by 50% or more.

Typically, when writing and testing a program or making short calculations, a user would like to obtain results within a few minutes; when carrying out long calculations with a working program it is usually adequate if results are obtained after a few hours or even days.

The time spent in tape handling will reach alarming proportions over the next few years unless some alternative means of bulk storage can be used for data requiring frequent or random access.

Computing facilities in the 1970s will most probably be based on a network of several

computers and data stores, with different degrees of connection between them. The computing capacity will have to be accessible from different parts of the site, with enough redundancy that computing continues when some machines or storage elements are out of action.

To restore man's ego in the face of electronics, it is a pleasure to tell the story of a human computer, William ["Wim"] Klein, a member of CERN's Theory Division since 1958. Wim Klein has been a calculating prodigy since his early school days and has entertained audiences for many years. Multiplication of any five-figure numbers takes a few seconds; even $1,388,978,361 \times 5,645,418,496 = 7,841,364,129,733,165,056$ he did completely in his head in 64 seconds.

● From the articles on pp162–175.

COMPILER'S NOTE

The September 1967 issue of the *CERN Courier* contains 26 fact-packed pages of valuable source material for IT historians. It charts the pioneering approach taken to a broad range of emergent computer applications, from automated film measurement to administrative data processing. The computing culture that was rapidly taking shape throughout the particle-physics community at that time would lead, barely 20 years later, to the creation of the World Wide Web at CERN. One might say that contemporary life today could not sustain its rate of progress had it not been for the development of subnuclear physics research.

- **Magnets for Research, Accelerator Technology & Industrial Applications**

For more information please visit:
www.bruker-est.com/basc-magnets.html

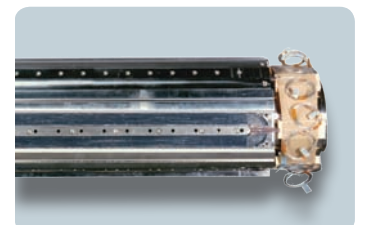
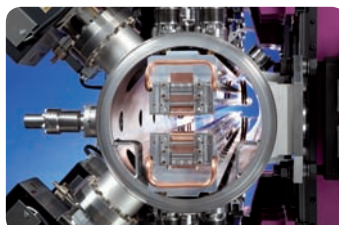
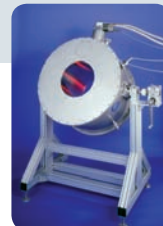
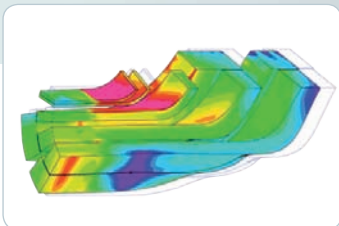

WHAT POWERS YOUR ACCELERATOR?

HV and RF Technology from L-3.

L-3 Electron Devices is leading the technology revolution with powerful solutions in all areas of high-energy particle physics. L-3 offers RF sources and high voltage switches to the world's leading accelerators and universities. Whether the application requires pulse or CW, UHF or microwave RF, L-3 has a klystron, IOT or TWT that can meet the demanding requirements of most systems. Our products have been supporting customers at SLAC, Argonne, LANL, Thomas Jefferson National Laboratory, Fermi and KEK, and L-3 can create a unique solution using our years of engineering knowledge and experience.

To learn more about L-3's innovative technology, visit L-3com.com/edd or e-mail us at wpt.marketing@L-3com.com.

Electron Devices



L-3com.com

Flip-Chip Service at X-ray Imatek S.L.

X-ray Imatek S.L. (XRI) offers flip-chip/bump-bonding services for research centers that are seeking to do small numbers of assemblies. XRI uses a FC-150 flip-chip bonding machine with precise reflow arm which makes possible to align and bump-bond a pixel detector with pixel pitch of $15\mu\text{m}$. Part of our service is to provide Sn/Pb bump growth on Silicon/Glass 4" diameter wafers. We can also provide Under-Bump-Metal (UBM) service on any chip/substrate shape.

For more information please contact us at
flip-chip@xray-imatek.com

Edificio EUREKA P2-M1,
Campus UAB,
08193 Bellaterra, Spain

www.xray-imatek.com



IPAC '10: accelerating to an international level

A new era of communication in the particle-accelerator community began in Kyoto in May, with the first in a new international series of annual particle-accelerator conferences.

For many years members of the particle accelerator community have come together on a more or less regional basis to consider progress in their field and present the state of the art. North America has held the Particle Accelerator Conference (PAC) in “odd” years since the 1960s; the European Particle Accelerator Conference (EPAC) has run in “even” years since 1988; and the first Asian Particle Accelerator Conference (APAC) started on a three-year cycle in 1998. Now, as particle accelerators are beginning to exist worldwide, a new era has begun with a merging of the conferences into the International Particle Accelerator Conference (IPAC), which will alternate between America, Asia and Europe on a three-yearly basis.

The first in the series, IPAC '10, took place at the Kyoto International Conference Centre on 23–28 May. It was an international affair, with close to 1250 full-time participants coming from more than 30 different countries in Africa, Asia, the Americas, Australasia and Europe. The conference was organized by the Science Council of Japan, the Physical Society of Japan, the Particle Accelerator Society of Japan and the Atomic Energy Society of Japan under the auspices of the Asian Committee for Future Accelerators (ACFA), the European Physical Society Accelerator Group, the American Physical Society Division of Physics of Beams and institutes in North America involved in PAC.

Shin-ichi Kurokawa and Katsunobu Oide, respectively honorary chair and chair of the Organizing Committee, Akira Noda, chair of the Scientific Programme Committee (SPC), and Toshiyuki Shirai, chair of the Local Organizing Committee, had the honour of opening the inaugural conference. Then, setting an appropriate international flavour, Albrecht Wagner, previously director of DESY and a former chair of the International Committee for Future Accelerators, opened the scientific programme with a presentation on “International Collaboration with High Energy Accelerators”.

The scientific programme

The programme itself spanned four and a half days, with plenary sessions on Monday and Friday mornings, and on Thursday afternoon. All of the other sessions were composed of two parallel oral sessions, while lively poster sessions took place at the end of each afternoon. The scientific programme was developed by the IPAC '10 SPC, a truly international body with members composed 50% from Asia and 50% from Europe and North America. All together, there were 54 invited talks, 45 contributed oral presentations and

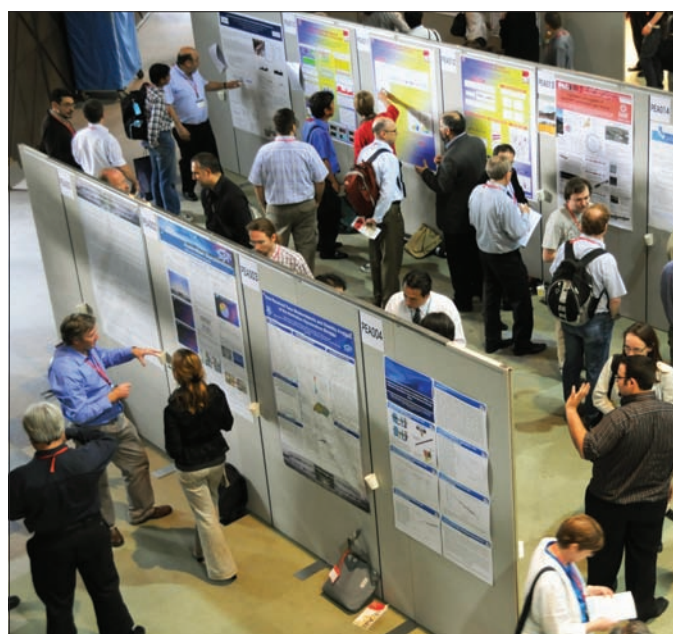

The poster sessions featured a total of 1800 poster displays, covering all aspects of particle accelerators. (Photos courtesy IPAC '10.)

1800 posters. An industrial exhibition also took place during the first three days of the conference, in which 87 companies presented their hi-tech products and services.

CERN's LHC had a central role in many of the presentations, both in talks and in posters. This was the first major accelerator conference to follow the machine's successful restart in November 2009 and hence the first opportunity to present measurements from commissioning with beam. CERN's Steve Myers set the scene in the opening plenary session, beginning with the repairs and consolidation following the incident that had brought commissioning to an early standstill in September 2008 (p27). Since the end of March the machine has been operating at 7 TeV in the centre of mass, with alternating periods of beam commissioning and physics data-taking. In the first two months, the peak luminosity increased by two orders of magnitude, with a goal of reaching $10^{32} \text{ cm}^{-2} \text{ s}^{-1}$ before the end of 2010. Myers paid tribute to the high quality and reliability of many of the systems, which had made the commissioning fast, as well as to the dedication of the many teams and collaborating ▸

institutes that had made it all possible.

Other talks and poster presentations focused on more specific aspects of the LHC. The cryogenic system, for example, is the largest in the world in terms of refrigeration capacity (about 140 kW at 4.5 K and 20 kW at 1.8 K), distributed superfluid helium (24 km of superconducting magnets for a total mass of 36 000 tonnes below 2 K) and cryogen inventory (more than 130 tonnes of helium). The first operating experience with beams has already shown an availability of 90% and the learning process continues as the cryogenics teams resolve how to improve weaker points in the system, reducing both the number of unplanned stops and the recovery time after a stop. The control of the beam optics round all 27 km of each of the two rings and the precise alignment (to a tenth of a millimetre) of each individual element of the machine has been another success story. The optics (determining the beam size at any point of the machine) is based on a calculated magnetic model that provides the expected relationship between current and field in the magnets. The early phase of commissioning immediately showed the high quality of both the optics modelling and the magnetic model, which were based on measurements taken during five years of magnet production and testing. The orbit is within the specifications thanks to the alignment accuracy and its correction has raised no important issues.

Another vitally important aspect of LHC operation is the machine-protection system. Safe operation requires many systems for beam dumping, beam interlocks, beam instrumentation, equipment monitoring, collimators and absorbers, etc. The stored energy in the LHC beams is therefore being increased in steps, with operation for physics in between. At each step the machine protection is validated for operational conditions. By the time of the conference the energy stored in each of the beams already exceeded 100 kJ. By the end of 2010 this energy will have increased up to 30 MJ – well above the stored beam energy at Fermilab's Tevatron, which amounts to about 1 MJ.

Pushing back the luminosity frontier belongs to the much smaller electron-positron storage rings that form the particle “factories”, in particular for studying the physics of B particles, as at PEP-II at SLAC and KEKB at KEK. Nobel laureate Makoto Kobayashi emphasized the importance of the B factories in establishing the mechanism of CP violation in the six-quark model, for which he and Toshihide Maskawa shared the Nobel prize in 2008 (*CERN Courier* November 2008 p6). In the following talk, Mika Masuzawa of KEK described how the physics community has now set a target of an integrated luminosity of 50–75 ab^{-1} for the exploration of new physics beyond the Standard Model. At a luminosity of $2 \times 10^{34} \text{ cm}^{-2} \text{ s}^{-1}$ (near the KEKB peak) this would take more than 100 years, so there is a need for machines of much higher luminosity. Two projects that are currently in advanced stages of design, SuperKEKB in Japan and SuperB in Italy, aim to deliver a luminosity some 40–50 times higher ($0.8 \times 10^{36} \text{ cm}^{-2} \text{ s}^{-1}$ and $1 \times 10^{36} \text{ cm}^{-2} \text{ s}^{-1}$ respectively).

Historically, particle accelerators developed as tools for high-energy particle physics and it was these that originally formed the basis for the associated conferences. The past decade, however, has seen an explosion in the number of accelerators used as light sources. There are now some 70 light sources in the world, serving a community of more than 100 000 users. In general, these users are demanding smaller beams and shorter pulses. One result is that light sources are now based not only on electron storage rings, but

The student factor

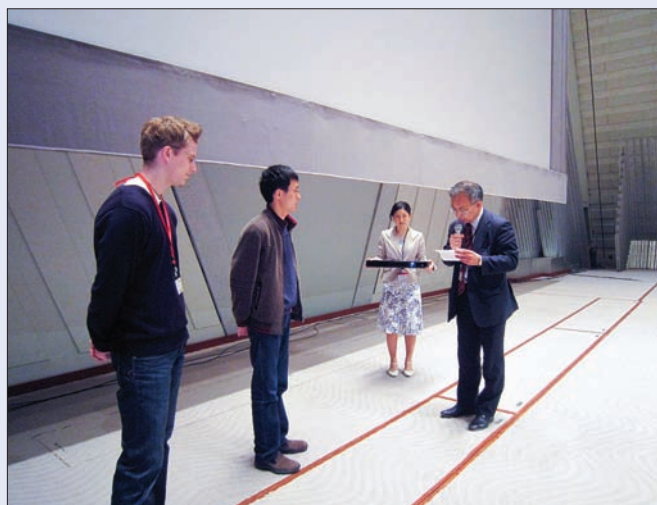

Marcel Ruf and Houjun Qian receive their prizes for the best student poster from Anka Noda, chair of the Scientific Programme Committee.

Students are an essential factor in sustaining any research field – and particle accelerator R&D is no exception. The inclusion of students was an important part of the biennial EPAC meetings where the opportunity to attend a major international conference in their field was supported through contributions from the various European accelerator laboratories. While EPAC's two-year cycle did not fit ideally with the normal 3-year doctoral student term, IPAC now provides a perfect fit.

Nearly 100 young scientists from around the world were able to attend IPAC '10 thanks to sponsorship from societies, institutes and laboratories. One important aspect was their contributions to the poster sessions. Prizes for best student posters were awarded to Houjun Qian of Brookhaven National Laboratory and Tsinghua University in Beijing, for the contribution on “Experimental Studies of Thermal Emittance of the Mg Cathode at the NSLS SDL” and to Marcel Ruf, University of Erlangen-Nurnberg, for the contribution “Beam Position Monitoring Based on Higher Beam Harmonics for Application in Compact Medical and Industrial Linear Electron Accelerators”.

The IPAC '10 organizers thank the following for their sponsorship for the students: APS-DPB, CEA, CELLS-ALBA, CERN, CIEMAT, CNRS/IN2P3, DESY, DIAMOND, EPS-AG, ESRF, Foundation for High Energy Accelerator Science, GSI, ICR Kyoto University, INFN, Italian Physical Society, IUPAP, JAEA, Japan Society for the Promotion of Science, JASRI, Kyoto Chamber of Commerce and Industry, Kyoto City, Kyoto Prefecture, KEK, Kyoto University, MAX-lab, MSL, NIRS, Osaka University, POSTECH, PSI, RCNP, Osaka University, RIKEN, STFC, Synchrotron SOLEIL and UST.

increasingly on free-electron lasers (FELs). These can provide short pulses of coherent radiation, which are valuable for probing rapidly changing processes.

John Galayda of the SLAC National Accelerator Laboratory presented the field's equivalent of the LHC – the Linac Coherent Light

Source (LCLS), the world's first X-ray FEL to operate in the photon energy range 820–8200 eV. The LCLS uses an electron beam produced by a 1 km section of SLAC's famous linac. It produced its first X-ray laser beam on 10 April 2009 and the first run for users took place between October and December 2009. Eleven successful experiments in atomic, molecular and optical science collected some 200 TB of data. Today it is routinely producing X-ray pulses with an energy of a few millijoules across the operating wavelength range.

Femtosecond X-ray pulses at linac-driven FELs such as the LCLS have a great scientific potential. "Pump-probe" experiments at these facilities aim to use X-rays (the probe) to produce time-resolved information at the atomic scale on a sample that has been excited (pumped) with a laser. Studies at the LCLS have already demonstrated an optical timing system based on stabilized fibre links that provide the required synchronization at less than 20 fs.

In Europe, FLASH, the FEL-user facility at DESY, covers a wavelength range of 6.5–50 nm and pulse durations of 10–50 fs. An upgrade started in autumn 2009 to increase the beam energy to 1.2 GeV – and reduce the shortest photon wavelength to 4.5 nm – by installing a seventh superconducting accelerating module, which is also a prototype for the European X-ray FEL project, XFEL.

Globally, there has been continued growth in the number of synchrotron light sources, with new machines coming on line to satisfy the demands of a rapidly expanded user community, particularly in the areas of biology and life sciences. New facilities include PETRA III at DESY, the Shanghai Synchrotron Radiation Facility in China, the Taiwan Photon Source in South-East Asia and the SESAME facility under construction in the Middle East. Older facilities are also responding to increasing demands from the users. In Japan, for example, a team at the Spring-8 storage ring is developing a system to provide short-pulse X-rays using crab cavities to tilt the beam pulses to produce X-ray bunches that are sliced to provide sub-picosecond pulses. A new XFEL machine is also under construction at the Spring-8 laboratory and, in Italy, FERMI@Elettra is a new FEL being built at the home of the Elettra synchrotron-radiation source to supply photons at wavelengths from 100 nm down to 4 nm. In Russia, the Budker Institute of Nuclear Physics in Novosibirsk has begun operating the world's first multiorbit energy-recovery linac serving two FELs at present (*CERN Courier* July/August 2010 p10).

Developing applications

Accelerators play a key role not only in research in life sciences, but also in applications in medicine. Accelerator pioneer Robert Wilson first proposed using protons and light ions for cancer therapy more than 60 years ago. Today there are five carbon-ion therapy facilities around the world, with more to come. The Japanese, in particular, are making impressive headway in the field, with more than 10 years of experience at the Heavy-Ion Medical Accelerator in Chiba (HIMAC), where a new treatment facility is being constructed (*CERN Courier* June 2010 p22). The IPAC conference followed a week after a meeting of the Particle Therapy Co-Operative Group in Chiba.

Other developing areas for the application of particle accelerators figured in the closing plenary sessions, with talks from Norbert Holtkamp, principal deputy director-general of ITER, on energy-related developments, and by Jasper Kirkby of CERN, on the use of particle beams in climate research. Finally, Johannes Bluemer, of the Karlsruhe Institute of Technology, brought a different perspec-

JACoW: accelerating proceedings



Christine Petit-Jean-Genaz, CERN, and Volker Schaa (right), GSI, receive the award for services to the accelerator community from Katsunobu Oide, chair of the Organizing Committee.

The proceedings of IPAC '10 are published on the Joint Accelerator Conferences Website (JACoW) located and maintained at CERN and mirrored at KEK. Originally created for the publication of the proceedings of APAC, EPAC, and PAC, the site now hosts the proceedings of 16 conferences related to accelerator research (*CERN Courier* March 2003 p9). Over 100 sets of proceedings have been published to date, and more than half a million contributions are downloaded from the European site each year.

JACoW's goal of publishing speedily and efficiently was achieved in magnificent style for IPAC '10. With a strong international team, the "pre-press" version of the proceedings was available on-line on the last day of the conference via the Scientific Programme Management System (SPMS), the tool developed by the collaboration for the management of all contributions to the scientific programme. Exactly three weeks later, 1569 papers were published in final form on the JACoW site.

This year, ACFA and the IPAC '10 organizing committee recognized the JACoW collaboration's achievement with an award for services to the accelerator community. On receiving the prize on behalf of the collaboration, Volker Shaa and Christine Petit-Jean-Genaz, chair and deputy-chair of the JACoW collaboration, respectively, underlined that without laboratory support for the JACoW effort, such results would not be possible. The JACoW site is totally accessible and is free of charge for the community. There is however a cost, albeit small, for the laboratories where a few members of staff dedicate a percentage of their time to JACoW, namely, CERN, DESY, Fermilab, GSI and KEK.

• See www.jacow.org.

tive, when he looked to the most powerful accelerators – those that exist in nature, providing cosmic rays with energies up to 100 EeV. These energies – and the multikilometre scale of the Pierre Auger Project to study these ultrahigh-energy cosmic rays – extend even further the superlatives reached by the LHC. ▷

INTEGRATED

2D/3D BEAM OPTICS & CHARGED PARTICLE TRAJECTORY ANALYSIS SOFTWARE



INTEGRATED field solvers have been proven in a diverse range of applications for 25 years. Our Boundary Element Method (**BEM**), Finite Element Method (**FEM**), and **HYBRID** solvers are available in the same package to give you a greater choice. Now, you can independently verify the solution within one program, and avoid the time and effort of verifying through a second program.

Fast. Accurate. Easy-to-use.

- Very short learning curve; no scripting required
- Design optimization by parametric analysis
- Link to CAD packages for true representation of complex geometric shapes

Analyze and model:

- Beams
- Ions
- Charged particles
- Beam optics
- Electron guns

NEW:

- Minimum 10x faster speed of calculation
- Meniscus plasma calculation in 2D

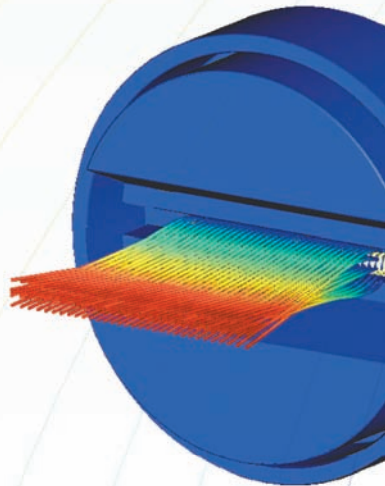

TRY OUR SOFTWARE FOR 30 DAYS!

CALL FOR A FREE EVALUATION AND START IMPROVING PRODUCTIVITY TODAY.

A live demo is also available.



INTEGRATED
ENGINEERING SOFTWARE

Call +1 204.632.5636
email info@integratedsoft.com
or visit www.integratedsoft.com



IPAC '10



The new logo for IPAC figures top right on the poster for the meeting in 2011, when the conference moves to Europe.

In addition to the standard sessions, the conference provided the opportunity to present a number of prizes. ACFA and IPAC together awarded prizes for outstanding work in the field of accelerators to Steve Myers of CERN, Jie Wei of Tsinghua University, and Mei Bai of Brookhaven National Laboratory (*CERN Courier* March 2010 p30). There were also prizes for the best student posters (p16). A further prize, decided by the IPAC '10 organizing committee, was presented to the JACoW collaboration for its service to the accelerator community (p17). Lastly, Caterina Biscari of INFN-LNF received a plaque on behalf of her colleague Claudio Federici, who won the competition to design a logo for the new IPAC series.

The first conference in the new international series has thus set the scene for the future meetings. The second IPAC will take place in San Sebastián, Spain (September 2011), and the third in New Orleans, in the US (May 2012). In this way the collaboration between the three regions, steadily enhanced in recent years, should continue to grow to the benefit of the worldwide accelerator community.

Further reading

The proceedings are published on the JACoW site: www.jacow.org.

Résumé

IPAC '10 : l'accélération à l'échelle internationale

Une nouvelle ère a commencé cette année avec l'inauguration de la Conférence internationale sur les accélérateurs de particules (IPAC), fusionnant les différentes conférences régionales dans le domaine. L'IPAC aura lieu tous les ans alternativement en Amérique, en Asie et en Europe. La première édition (IPAC '10), qui s'est tenue du 23 au 28 mai au Centre international de conférences de Kyoto, a été vraiment internationale, puisqu'elle a rassemblé près de 1250 participants à plein temps venant de plus de 30 pays différents d'Afrique, des Amériques, d'Australasie et d'Europe. Le démarrage du Grand collisionneur de hadrons, les progrès des collisionneurs électron-positon de luminosité élevée et l'évolution des sources de lumière comptaient parmi les thèmes marquants de la Conférence.

Christine Sutton, in collaboration with **Gianluigi Arduini**, **Oliver Brüning** and **Christine Petit-Jean-Genaz**, CERN.

If you need Metals & Materials...

Pure Metals, Alloys, Polymers, Ceramics, as well as many Composites and Compounds in various forms including foil, rod, tube, wire, powder, etc.

...you need
Goodfellow

Goodfellow Cambridge Limited, Ermine Business Park, Huntingdon, PE29 6WR

Tel: 0800 731 4653 OR +44 1480 424 800, Fax: 0800 328 7689 OR +44 1480 424 900

E-mail: info@goodfellow.com
www.goodfellow.com

CRYO-CON[®]
Cryogenic Control Systems, Inc.



CRYOGENIC INSTRUMENTS

- TEMPERATURE CONTROLLERS
- TEMPERATURE MONITORS
- CRYOGENIC ACCESSORIES
- SCANNERS
- SENSORS



Visit our website for product specifications

www.cryocon.com

858-756-3900

sales@cryocon.com

Measuring magnetic field transients?

The Fast Digital Integrator FD12056 is the world's fastest and most sensitive voltage integrator.

For the first time it is possible to measure fast, low-level magnetic field disturbances such as eddy currents in a switched magnet.

A complete and upgradable solution for your most exacting magnetic measurements.

Now it's possible!

Designed at the CERN

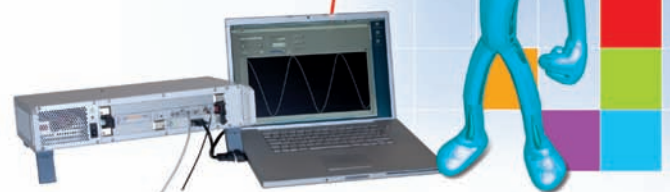

www.metrolab.com

METROLAB
Magnetic precision has a name



«Easy close» All-metal Angle Valves

Series 54, DN 16 - 63 (5/8" - 2 1/2")



THE «Challenger»

- «Hard-on-hard» sealing method
- Closing to stop, no torque wrench needed
- Maintenance-free, for UHV systems
- Protected CF knife-edge for rotatable flanges

Swiss Headquarters
Tel ++41 81 771 61 61
CH@vatvalve.com

VAT Benelux
Tel ++31 30 6018251
NL@vatvalve.com

VAT France
Tel 01 69 20 69 11
FR@vatvalve.com

VAT Germany
Tel (089) 46 50 15
DE@vatvalve.com

VAT U.K.
Tel 01926 452 753
UK@vatvalve.com

VAT USA
Tel (781) 935 1446
US@vatvalve.com

VAT Japan
Tel (045) 333 11 44
JP@vatvalve.com

VAT Korea
Tel 031 662 68 56
KR@vatvalve.com

VAT Taiwan
Tel 03 516 90 88
TW@vatvalve.com

VAT China
Tel 021 5854 4300
CN@vatvalve.com

VAT Singapore
Tel 0065 6252 5121
SG@vatvalve.com

www.vatvalve.com



L A K E S H O R E NEW MODEL 336 TEMPERATURE CONTROLLER



- 2 PID control loops provide 150 W total of low noise heater power
- Seamless measurement and control from 300 mK to 1505 K
- Custom label sensor inputs
- Intelligent Autotuning
- New user friendly front panel layout and keypad logic
- Standard Ethernet, USB, and IEEE-488
- ±10 V analog voltage outputs, alarms, and relays

FEATURING 4 STANDARD INPUTS & OUTPUTS

Complete your setup with Lake Shore's full line of temperature sensors and cryogenic accessories



LakeShore®

Phone: (614) 891-2244 Fax: (614) 818-1600
info@lakeshore.com www.lakeshore.com



Participants at EURORIB '10, held at Lamoura in the Jura mountains in France, pose for the traditional conference photo.

Europe charts future for radioactive beams

The EURORIB '10 conference provided the opportunity to promote scientific and technical collaboration on radioactive-ion-beam facilities in Europe, as [Antonella Del Rosso](#) reports.

These are exciting times for European nuclear physics, with several new facilities under study or under construction, including HIE-ISOLDE at CERN, the NuSTAR experiments at the Facility for Antiproton and Ion Research (FAIR) in Germany, the Selective Production of Exotic Species (SPES) project at the Legnaro National Laboratory in Italy and the Système de Production d'Ions Radioactifs en Ligne 2 (SPIRAL2) at the French national heavy-ion accelerator laboratory, GANIL. In addition, the nuclear-physics community is working on a common design for a future European isotope-separation on-line facility, EURISOL. To discuss the open issues and promote synergies among the different projects, the community met recently at the second European Radioactive Ion Beam Conference (EURORIB '10), held in Lamoura, France, on 6–11 June.

The new-generation facilities will all produce more intense radioactive ion beams (RIBs) to probe nuclear structure. "The use of RIBs to understand the nature of the nucleus started about 50 years ago and many unexpected discoveries have been made with this technique over the past two decades," explains Yorick Blumenfeld, spokesperson for the ISOLDE collaboration at CERN and chair of the EURORIB '10 conference.

One of the main goals of the EURORIB '10 conference was to allow

the European nuclear-physics community to share experiences and information about all of the various projects. "At the conference we had very active working groups on subjects like instrumentation and data acquisition," says Blumenfeld. "This was also done to try to develop common technical solutions, which could be used by several facilities and be moved between them. We think that it will be more efficient to be able to move instrumentation between the different sites than to design similar detectors for all of them and then use them only occasionally."

Two techniques

Both the present and future facilities for the production of RIBs are based on two basic techniques: the "in-flight fragmentation" and the "isotope separation on-line (ISOL)" types. For in-flight fragmentation, heavy nuclei are accelerated before hitting a thin target where fragmentation or fission reactions take place and produce many kinds of nuclei, including exotic ones. A magnetic separator selects the species that the various experiments want to study. "The advantage of this type of technique is that beams have high energy and the production process is fast. In this way, one can produce very short lived nuclei that are used to study the extremes of the ▷

nuclear chart,” explains Navin Alahari, deputy scientific co-ordinator at SPIRAL2. “On the other hand, the yields are low because the interactions happen in a thin target. Moreover, the beam has a large angular and energy spread.”

In the ISOL technique, a beam of light ions impinges on a thick target. In this case, fission or spallation reactions are induced with the exotic nuclei diffusing out of the heated target. After that, they are ionized and the species of interest are selected. Some experiments use such beams at rest, others use them after they are post accelerated. “The advantage is that in this case we use the full power of the beam, thus obtaining high intensities,” continues Navin. “Because the beams are post accelerated, they have a well defined energy and a small angular spread. The disadvantage is that the process of diffusion is slow and therefore one can only produce nuclei that have a relatively long lifetime, the lower limit being of the order of milliseconds. Some types of elements don’t even come out of the target, they get stuck because of their chemical properties.”

The EURORIB '10 conference provided the opportunity to promote collaboration and exchange between the communities using these techniques. “The two methods for producing radioactive ion beams complement each other in that precision studies – such as the investigation of the nuclear levels and the studies of the correlations between decay particles – need large intensities (therefore the ISOL-type facilities) and good beam quality, while the ‘in-flight fragmentation’ technique is really good for exploring high-energy nuclear excitations and the confines of the nuclear chart where lifetimes are very short,” confirms Valentina Ricciardi of GSI.

For the longer term, the ultimate goal of the ISOL community is to build the EURISOL facility. “We need so many intermediate facilities on the way to EURISOL because there are many new techniques that need to be explored,” says Faisal Azaiez, recently named director of l’Institut de Physique Nucléaire, Orsay. “After all of this preliminary work we will be able to converge and put together the best ideas in order to optimize the various processes and give birth to a common, state-of-the-art system.” A detailed design for this “ultimate” ISOL facility for Europe was devised during the EURISOL Design Study, funded partially by the European Commission, which lasted four and a half years and involved 20 European laboratories, including CERN.

Multiuser capability is an essential ingredient of the EURISOL concept, which is based on a superconducting continuous-wave linac capable of accelerating 5 mA of H⁻ ions to 1 GeV (5 MW beam power). The major part of the beam will be sent to a mercury converter-target where the neutrons produced will induce fission in six uranium-carbide targets surrounding the converter. An innovative magnetic beam-splitting system will create up to three additional 100 kW beams. These will impinge directly on solid targets to induce spallation reactions, which can populate the regions of the nuclear chart that are unattainable in fission reactions. After selection the radioactive beams can either be used at low energies or post accelerated in another superconducting linac with continuous energy variation up to 150 MeV/A for ¹³²Sn, for example. The high-energy neutron-rich beams such as ¹³²Sn, which will reach intensities of up to 10¹² particles a second, can then be fragmented to produce high intensities of many otherwise inaccessible neutron-rich nuclei.

“A choice for the location for EURISOL will have to be made in the coming years,” says Blumenfeld, who led the EURISOL design study. “The natural course would be to choose one of the sites of the new

Halos, magic numbers and radioactivity

Among the discoveries with RIBs are the unusual properties of light neutron-rich nuclei, which are interpreted in terms of a structure consisting of a compact core surrounded by a “halo” of neutrons. For example ¹¹Li, with eight neutrons, exhibits a dilute two-neutron halo that is the size of ²⁰⁸Pb (*CERN Courier* May 2004 p26). Also, there are open questions about the “magic numbers” in exotic nuclei, where the large imbalance between protons and neutrons induces structural changes. The magic numbers, usually associated with high degrees of stability, were considered to be immutable until a few years ago, when the nucleus ²⁸O (with 8 protons and 20 neutrons, both of which are magic numbers) was shown not to exist, despite the prediction by nuclear theorists that it should be strongly bound. Indeed, 16 has been shown to replace 20 as a magic number for neutron-rich nuclei and analogous effects have been found in many other regions of the chart of nuclides. Such changes are of great interest to nuclear astrophysicists, who must take them into account to understand the path of explosive nucleosynthesis in stars.

Furthermore, even though radioactivity was discovered more than a century ago, new types continue to emerge, such as two-proton radioactivity in which a nucleus emits two protons simultaneously (*CERN Courier* December 2002 p27). This phenomenon is present only in extremely neutron-deficient nuclei, which had not previously been synthesized. Finally, radioactive beams can provide stringent tests for the Standard Model of particle physics. For example the element V_{ud} of the Cabibbo-Kobayashi-Maskawa (quark-mixing) matrix is known with great precision, thanks to detailed studies of nuclear β-decay carried out at RIB facilities.

ISOL facilities, but a green-field site could also be considered.”

While Europe is on its way towards combining efforts and converging on the EURISOL project, Japan and North America (the US and Canada) are also very active. Speakers from these countries presented their new facilities at EURORIB '10 and, in some cases, even the first results. Seung-Woo Hong, at Sungkyunkwan University, Korea, for example, is leading the conceptual design project for a heavy-ion accelerator facility for producing RIBs using both the ISOL and the in-flight fragmentation techniques. “This shows that there is a lot of interest for this field all across the world, which is good news for our community,” comments Blumenfeld.

It is clear that nuclear physics is currently a lively field of research. This is easy to understand considering the many links it has with other disciplines and the variety of practical applications, which are becoming increasingly common. “Nuclear physics has a strong and direct link with astrophysics,” says Giovanni La Rana of the Italian National Institute of Nuclear Physics (INFN), describing one example. “Stars live because of nuclear reactions, and to understand how elements are synthesized in the stars scientists need information about nuclei involved in the reactions. Exotic nuclei are involved in the supernovae explosions and to study these processes, one needs masses, cross-sections and lifetimes of these nuclei. So far, the information is extrapolated from stable nuclei through theoretical

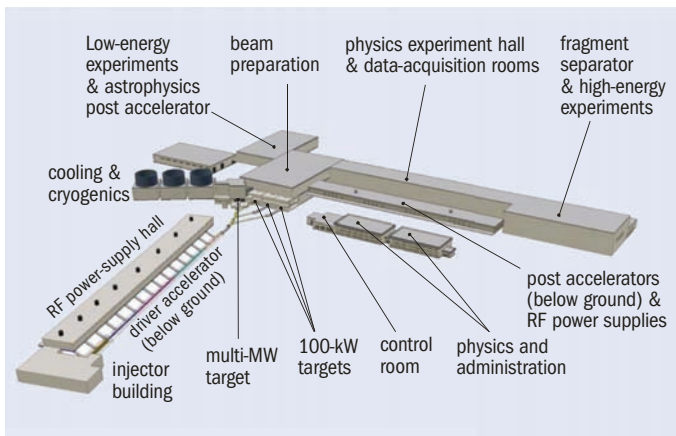

The EURISOL facility would serve many users with a variety of intense radioactive-ion beams. (Courtesy EURISOL Design Study.)

models, but the new facilities should give us access to these new exotic nuclei."

By contrast, Alexander Herlert, ISOLDE physics co-ordinator, cites applications closer to Earth. "Researchers implant radioactive nuclei into materials," he says. "Observing the decay, they can study the properties of the materials. This technique, complementary to other solid-state techniques, allows them to understand the structure of semiconductors and new types of materials." Nuclear-physics techniques also find application in the medical field, particularly in what is known as isotope harvesting. "Our facilities can produce all sorts of isotopes, basically anything," says Ulli Köster of the Institut Laue-Langevin, who presented the future perspectives for the field at the conference. "If the doctors need to test new isotopes for medical imaging or treatment, then we can produce them."

EURORIB '10 certainly revealed the present vitality in nuclear physics. The talks and discussion sessions underlined the close scientific and technical collaboration between the different RIB facilities, which is propelling the field towards a unified European perspective.

Résumé

L'Europe trace l'avenir des faisceaux radioactifs

La physique nucléaire est aujourd'hui un domaine de recherche très dynamique, ayant de nombreux liens avec d'autres disciplines et des applications pratiques variées. En Europe, plusieurs installations nouvelles de production de faisceaux d'ions radioactifs sont en construction ou à l'étude en France, en Allemagne et en Italie. Par ailleurs, la communauté européenne de physique nucléaire travaille actuellement à la conception conjointe d'EURISOL, future installation européenne à faisceaux d'ions radioactifs par séparation en ligne des isotopes. La deuxième édition de la Conférence internationale EURORIB (European Radioactive Ion Beam Conference – EURORIB '10) a permis de débattre des questions d'actualité et de favoriser des synergies entre les différents projets en la matière. Elle a confirmé que la physique nucléaire connaît actuellement une période passionnante en Europe.

Antonella Del Rosso, CERN.

Charge sensitive preamplifiers

perfect for radiation detection!

Gaussian shaping amplifiers



all product specifications can be found online at:

<http://cremat.com>

Cremat's charge sensitive preamplifiers (CSPs) can be used to read out pulse signals from radiation detectors as diverse as semiconductor detectors (e.g. Si, CdTe, CZT), scintillator-photodiode detectors, avalanche photodiodes, gas-based detectors such as ionization chambers and proportional counters, microchannel plate detectors, and photomultiplier tubes (PMTs).

Our CSPs and shaping amplifiers are epoxy sealed plug-in modules less than 1 in² in area.

We also have fully-assembled instrumentation

cremat
45 Union St
Watertown, MA
02472 USA
+1(617)527-6590
info@cremat.com



Neutron detection with scintillators: an alternative to He-3

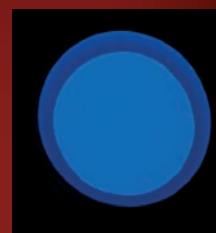
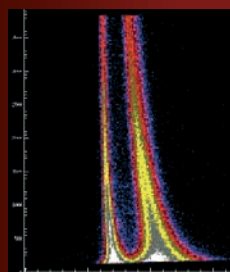

Lil(Eu), liquid cells
¹⁰B, Gd loading

SCIONIX Holland B.V.
Tel. +31 30 6570312
Fax. +31 30 6567563
Email. sales@scionix.nl
www.scionix.nl



Contact us for more information

Canada's bright future

Assured funding and the launch of a new facility promise

In this era of fiscal uncertainty, several key agencies in Canada have stepped up and made firm commitments to TRIUMF and the future of particle and nuclear physics in Canada. In March, TRIUMF's five-year core operating budget was renewed at the level of C\$222.3 million for the 2010–2015 period. Then, in mid-June, the final pieces of the funding puzzle were put into place for the launch of the new flagship Advanced Rare IsotopE Laboratory (ARIEL) facility at TRIUMF, when the Province of British Columbia announced its C\$30.7 million investment, completing the C\$63 million package. The project includes a new, high-power, superconducting radio-frequency electron linear accelerator for isotope production.

As Canada's national laboratory for particle and nuclear physics, TRIUMF is owned and operated by a consortium of 15 Canadian universities. Its core operating funds are supplied in five-year blocks by the federal Ministry of Industry through the National Research Council Canada. The previous five-year cycle ended on 31 March 2010; new funding for the laboratory for the 2010–2015 period was unveiled in March as part of the federal budget. The announcement completes a process of more than two years' effort to secure the funding. This included both an international review by some of the world's most accomplished scientists and an economic-impact study that analysed the direct, indirect and induced impacts on the provincial and federal economies of public spending at TRIUMF.

TRIUMF celebrated its 40th anniversary last year. Over the years it has evolved from covering only medium-energy nuclear physics to include high-energy physics, materials science, rare-isotope beam physics, accelerator science and technology, and most recently, nuclear medicine. TRIUMF regularly produces intense beams of exotic isotopes using proton beams of up to 50 kW extracted from the main 500 MeV cyclotron. These isotopes are produced and studied in the Isotope Separator and Accelerator (ISAC) facility, which includes an impressive suite of experiments and detectors for research in nuclear structure and nuclear astrophysics, and for tests of fundamental symmetries. TRIUMF recently completed an upgrade of the ISAC-II facility to provide acceleration of radioactive ions of up to 5 MeV/u. This linear accelerator was developed using superconducting radio-frequency cavities manufactured in Canada by PAVAC Industries in co-operation with TRIUMF. In nuclear medicine, TRIUMF has a 30-year history of producing medical isotopes using small cyclotrons in partnership with MDS Nordion for global sales and distribution.

The five-year vision

The federal contribution for operations will not support all of the TRIUMF community's aspirations (nor should it), but it does support and strengthen key initiatives in particle physics, nuclear physics, materials science, nuclear medicine and accelerator science and technology. In nuclear physics, the programme will focus on exploiting the existing ISAC-I and ISAC-II facilities. An aggressive programme in target development will continue and deliver beams



Illustration of the ARIEL facility. The new isotope-production target hall would sit between existing TRIUMF auditorium (right) and the ISAC experimental hall (left).



Federal and provincial officials announce the launch of the ARIEL project. Left to right: British Columbia Premier Gordon Campbell; federal minister Stockwell Day; director of TRIUMF Nigel Lockyer; University of Victoria vice-president, Howard Brunt.



The TRIUMF laboratory site. (Pictures courtesy TRIUMF.)

e in subatomic physics

...e a secure future for the TRIUMF laboratory in Vancouver.

of novel isotopes from actinide targets for physics experiments in the next 2–3 years. A programme for the production and characterization of uranium-carbide foils for use in ISAC has begun and the first physics run using novel isotopes from actinides is scheduled for December 2010.

In materials science, construction work on additional muon beam-lines will be completed to offer greater flexibility and more time for scientific usage. A new initiative in nuclear medicine is being launched that expands TRIUMF's historic activities in medical-isotope production into radiochemistry for the development and preclinical qualification of new radiotracers. The nuclear-medicine programme will include new equipment, full-time personnel and stronger partnerships across Canada.

In particle physics, the ATLAS Canada Tier-1 Data Centre will continue its operations; it serves as one of the 10 global data-storage and distribution centres for physics data from the ATLAS experiment at CERN's LHC. Canada's involvement in the Japan-based Tokai-to-Kamioka neutrino experiment will continue to receive support from TRIUMF as the research moves into the data-collection and analysis phase.

ARIEL takes off

The ARIEL facility will be the new flagship of the TRIUMF programme, which includes a new underground beam tunnel surrounding a next-generation linear accelerator – the e-linac, a project led by the University of Victoria. This facility substantially expands TRIUMF's isotope-production capabilities by adding the technique of photo-fission to the suite of available technologies. Canada will be unique in having electron- and proton-based capabilities for isotope production within the same laboratory. Moreover, for the first time in 35 years, TRIUMF's main cyclotron will have a fully fledged younger sibling to drive the breadth of the laboratory's research.

The lower floors of ARIEL will house the e-linac, which will produce an intense beam of electrons up to 50 MeV. An underground beam tunnel will connect the accelerator to the isotope-production area, where the beam of electrons will strike a convertor to create an intense beam of photons via bremsstrahlung. This beam will in turn be directed at targets made of beryllium, tantalum or actinide materials, for example. The isotopes will be extracted, separated and accelerated in real time and sent to the ISAC experimental areas.

The focus of ARIEL will be on "isotopes for physics and medicine". In terms of nuclear physics with rare isotopes, ARIEL is expected to increase TRIUMF's annual scientific productivity by a factor of 2–3 above current levels by providing a second primary "engine" for producing isotopes. ISAC will move from being a "one-at-a-time" facility to running several experiments simultaneously. The e-linac will expand the materials-science capabilities at TRIUMF by enabling high-volume production of lithium-8 for β -NMR studies using a beryllium target. In terms of isotopes for medicine, the facility is

intended to develop and study next-generation medical isotopes that may have applications in therapy (e.g. via alpha emission). ARIEL will also be used to demonstrate and benchmark the use of photo-fission technology for larger-scale production of key medical isotopes that are currently only produced in reactors, such as $^{99}\text{Mo}/^{99\text{m}}\text{Tc}$ (*CERN Courier* May 2010 p7). Photo-fission at ARIEL could produce at least one six-day Curie of ^{99}Mo per gram of natural uranium target material for a 100 kW irradiation period.

Construction of the ARIEL facility and e-linac began on 1 July, providing immediate stimulus to the civil-construction and technical communities in British Columbia and Canada. The facility will be completed in 2013 and the e-linac will then be installed. Isotope production for physics and medicine will be commissioned in 2014 and round-the-clock operations will become routine in 2015. ARIEL is designed to support two target stations – one initially for electrons and a future one for a new proton beamline extracted from the main 500 MeV cyclotron.

The e-linac will begin with a 30 MeV, 100 kW beam by 2014, with plans for it to be upgraded to a full 500 kW beam in the 2015–2020 era. The superconducting radio-frequency technology selected for the accelerator expands an emerging core competency at TRIUMF in partnership with a local electron-beam welding company, PAVAC Industries. The e-linac will be built using 1.3 GHz technology, recognizing the global move to parameters similar to those of the TESLA and International Linear Collider projects. The injector cryomodule is being designed and constructed in collaboration with India's Variable Energy Cyclotron Centre in Kolkata.

With a broad set of opportunities and programmes facing it, TRIUMF is optimistic about the next decade of scientific activity. Together with its national and international partners, the laboratory hopes to bring a "gold medal" home to Canada in subatomic physics.

Résumé

Le brillant avenir du Canada en physique subatomique

TRIUMPH, le laboratoire national canadien de physique des particules, a évolué au fil du temps pour se consacrer aujourd'hui également à la science des matériaux, à la physique des faisceaux d'isotopes rares et, plus récemment, à la médecine nucléaire. En mars, le budget d'exploitation sur cinq ans du laboratoire a été reconduit à hauteur de 222,3 millions de dollars canadiens pour la période 2010–2015. À la mi-juin, les dernières pièces du puzzle budgétaire ont été ajoutées lorsque le gouvernement de la Colombie-Britannique annonçait qu'il accordait une subvention de 30,7 millions pour la construction de la nouvelle installation ARIEL (Advanced Rare IsotopE Laboratory), venant ainsi compléter le projet global s'élevant à 63 millions.

Tim Meyer, TRIUMF.

X-Ray Detector

XR-100CR at **149 eV FWHM** Resolution

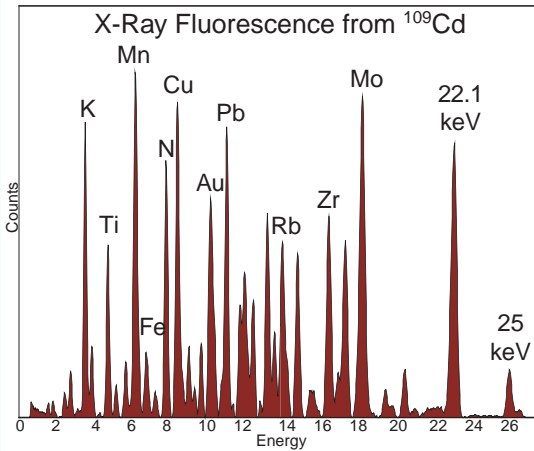

No Liquid Nitrogen

Solid State Design

Easy to Use

Low Cost

APPLICATIONS

- Nuclear Physics
- Synchrotron Radiation
- High Energy Physics
- Neutron Experiments
- Astrophysics
- Research & Teaching
- Nuclear Medicine
- X-Ray Fluorescence

Complete X-Ray Spectrometer

INCLUDES

- 1 X-Ray Detector and Pre-amplifier
- 2 Digital Pulse Processor and MCA
- 3 Power Supply



7 x 10 x 2.5 cm (2.7 x 3.9 x 1 in)

The X-123 is a complete X-Ray Detector System in one small box that fits in your hand.

Features of the X-123:

- Simple to Operate
- Low Power (1.2 Watts)
- Small Size
- USB and RS232 Communication
- Accommodates all Amptek Detectors



XR100CR X-Ray Detector with PX4 Digital Pulse Processor, Power Supply, Shaping Amplifier & MCA



XR100CR fitted for vacuum applications

Visit Us Now
www.amptek.com

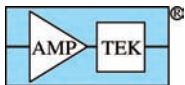

AMPTEK Inc. 14 DeAngelo Drive, Bedford, MA 01730-2204 USA

Tel: +1 (781) 275-2242 Fax: +1 (781) 275-3470

E-mail: sales@amptek.com www.amptek.com

Wide-Band Current Monitor



Pearson Electronics designs and manufactures custom Current Monitors for use in the beam tube, and large aperture clamp-on Current Monitors applied outside the beam tube.

Pearson Monitors measure sub-milliamp currents. Pulse rise times as fast as 1.5 nanoseconds can be viewed accurately. Many clamp-on and fixed aperture models are in stock and available for immediate delivery.

Contact Pearson Electronics for application information.

Pearson Electronics

4009 Transport St. Palo Alto, CA 94303 USA
Telephone: (650) 494-6444 FAX (650) 494-6716
www.pearsonelectronics.com



We combine precision with passion.



And research projects with our know-how.

Complex UHV systems for fusion and accelerator technologies

Benefit from our wide range of services:

development, engineering and design, production, joining technologies, cleaning technologies meeting UHV requirements, clean room assemblies, documented inspections and testing.

thermodynamicscompetent
www.reuter-technologie.de



The subtle side of superconductivity

Lucio Rossi describes the simple but rather devious fault in the interconnection system that brought the LHC to a halt in September 2008, and looks at what remedies have been made.

The LHC is probably the largest and most complex scientific instrument ever built. It relies on superconductivity, which plays a fundamental role because it allows magnetic fields in excess of 8 T to be reached. Combined with the radius of curvature of 2.804 km in the dipole (bending) magnets, this field enables proton beams to reach energies of 7 TeV, almost an order of magnitude higher than in previous accelerators. In total there are 1734 large, twin-aperture superconducting magnets, which include the backbone of 1232 main dipoles, each 15 m long. There are also 7724 smaller superconducting corrector magnets. To reach the design performance nearly all of the magnets are cooled with superfluid helium to 1.9 K. The total stored magnetic energy will be about 9000 MJ when running with the dipoles at 8.3 T and a beam energy of 7 TeV.

After 25 years from conception via R&D and construction to commissioning, the LHC started up in spectacular fashion on 10 September 2008 (*CERN Courier* October 2008 p7). The success of this first commissioning with beam demonstrated the excellent field quality and geometry of the magnets, their precise alignment and good stability, the accuracy of the power supply and the successful operation of the highly complex 1.9 K cryogenic system. Only nine days later, however, in the course of hardware commissioning, a severe incident occurred in sector 3-4 during a ramp of the main dipole current to 9.3 kA (corresponding to a magnetic field of about 6.5 T). It was the final ramp before definitive commissioning of all eight sectors of the machine for operation at 8.6 kA and, hence, an energy of 5 TeV. Many magnets quenched and eventually helium was released into the tunnel and general power was lost in the sector. The incident led to a delay of more than a year before the physics programme began successfully in November 2009 (*CERN Courier* January/February 2010 p24).

Collateral damage

The first inspection of the LHC tunnel after the incident revealed considerable damage along a zone about 750 m long. There was deformation of connections, electrical faults, perforation of the helium vessel, local destruction of the beam tube with heavy pollution by debris including fragments of multilayer insulation, breakage or damage of cold support posts, breaches in the interconnection

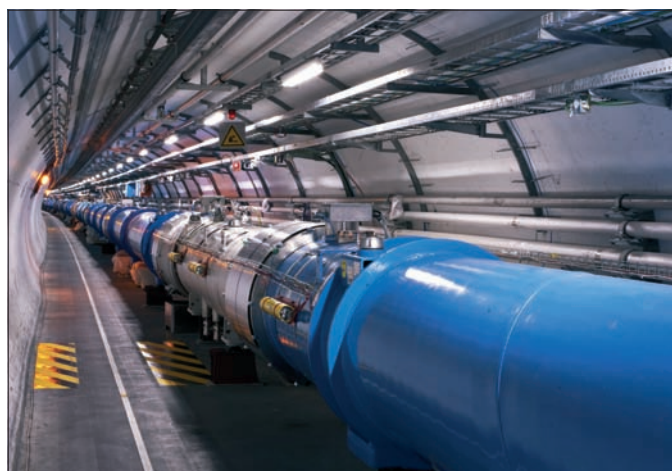

Sector 3-4, fully repaired and ready for the first LHC collisions.

bellows, damage to the warm jacks that support the magnets and cracks in the tunnel floor. The pollution of the beam tubes from tiny confetti-like fragments of insulation extended much further, spanning the sector's full 3 km-long arc. A task force led by Philippe Lebrun was immediately set up to analyse the incident and propose remedies. Within a month, CERN published the first interim report, followed by a more detailed second report in December 2008 (*CERN Courier* January/February 2009 p6). The final report was published at the end of March 2009 (Bajko *et al.* 2009).

It soon became clear that the root of the incident lay with a single fault in an electrical connection between two adjacent magnets, which had led to extensive collateral damage. A defective joint had created a small resistive zone in a superconducting busbar designed to carry a maximum current of 13 kA. It was a small fault in a relatively low-tech system, but it had dramatic consequences, thanks to the subtleties of superconductivity.

Before discussing this in more detail, it is worth describing the magnet powering and the scheme designed to protect the magnets when a quench occurs. In a quench, a conductor rapidly changes from being superconducting (with no resistance) to being normally conducting (resistive). This transition creates a sudden heating ▷

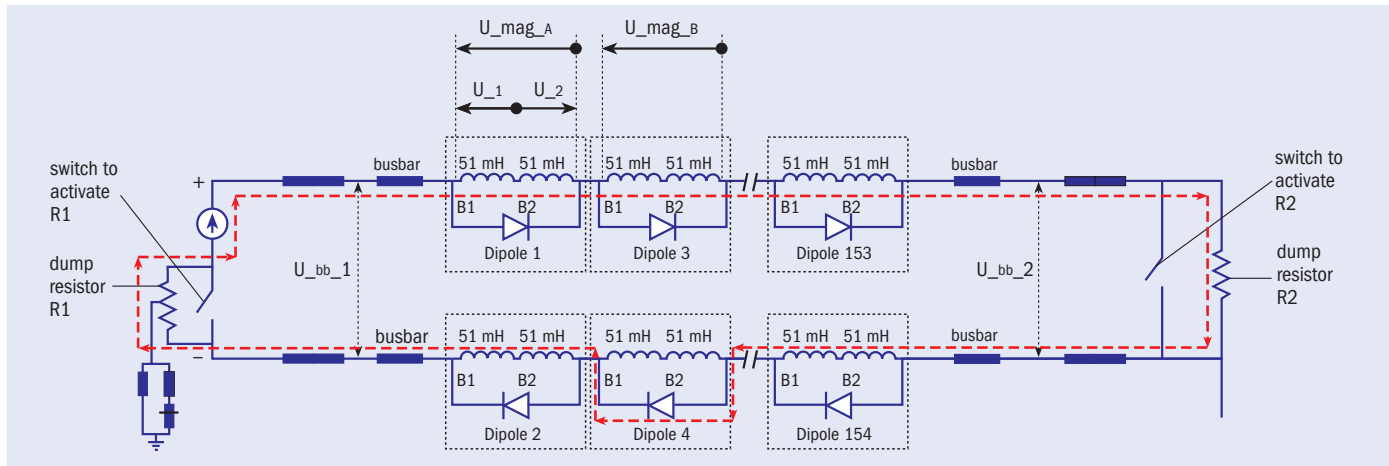

Fig. 1. The protection scheme of the LHC magnets. Magnet coils are connected in series and bypassed by a diode if there is a voltage rise. The path of the current is shown for the case of one quench (dipole 4 in this picture) after about 1 s, when all current has bypassed the quenched coil. At this stage the current passes through the dump resistors (R1 and R2), but in the circuit as a whole it is still very close to its initial high value.

effect in the resistive region. This needs to be controlled swiftly to avoid permanent damage to a magnet because the conductor can no longer sustain the high current, and the magnetic energy – about 7 MJ per dipole magnet – is converted into heat.

Busbars and splices

The main magnets of the LHC are connected electrically in a series via 13 kA superconducting busbars in eight main circuits, one per sector. Figure 1 shows a simplified version of the powering and protection scheme for one sector. The 154 dipoles in the sector are powered in series from one 13 kA power converter – with a dump resistance connected in parallel. The quench-detection system (QDS) monitors for resistive transitions in a magnet by comparing the voltages across the two apertures. When the onset of a quench is detected the system switches in the dump resistor. The inductance, L , of the whole circuit and its resistance, R (determined by the current and maximum voltage), give a $1/e$ discharge time, L/R , of 104 s, which is far too long for the magnet to survive. Each magnet therefore has a cold bypass-diode and heaters on the coils. As soon as a resistive transition is detected the heaters are fired so as to quench the coils in less than 50 ms. The subsequent sudden rise in voltage turns on the diodes so that they conduct and the current in the quenched coils decays to almost zero in less than 1 s. Meanwhile, all of the unquenched magnets in the sector and the busbars that bypass the quenched coils continue to carry the full current.

The busbars, in which the diodes are inserted, not only bypass any quenched magnet(s) electrically but also serve as a connection between adjacent magnets. So during a magnet quench the busbars carry the overall circuit current, decaying with a time constant of 104 s at the interconnections as well as in the quenched magnet(s). These busbars consist of a superconducting cable that is thermally and electrically coupled to a copper stabilizer along its whole length. The copper cross-section of the stabilizer is designed to be sufficient to carry the current safely, with no damage to the busbar, for the 104-second long discharge even if its superconducting cable is driven into the normal state.

In the case of the incident on 19 September 2008, analysis revealed that a sudden increase of the voltage occurred in the main

dipole circuit in sector 3-4, such that the power supply could not deliver the required current. This initiated a fast de-ramp of the magnets, discharging their energy in the dumping system. The discharge was faster than the nominal time constant of 104 s and the circuit quickly became divided into two branches, indicating the presence of a short-circuit. Several magnets quenched.

The basic fault appears to have been a defective joint in the 13 kA connection between superconducting cables in two adjacent magnets. As figure 2 shows, soft soldering based on tin-silver alloy is used not only to splice the superconducting cable but also to connect the copper stabilizer of the interconnection to both the cable joint and the stabilizing copper of the busbar. When finished, the connection looks like a continuation of the busbars that run along the whole length of the magnet system. The splice between superconducting cables is specified to have a resistance below $0.6 \text{ n}\Omega$ at 1.9 K. The actual results on samples during production showed an average of $0.2 \text{ n}\Omega$ with a variance of less than $0.1 \text{ n}\Omega$. The resistance of the splice that failed was later evaluated to have been around $220 \text{ n}\Omega$.

As they are superconducting, the busbars also have a QDS. This did not intercept the fault, however, because it was not sensitive enough to detect the approximately 2 mV voltage of the resistive zone; the sensitivity was, in fact, 300 mV with an intervention threshold of 1 V. It was subsequently found that, during a current plateau at 7 kA the previous day, sensors on the magnet had indicated a small but distinct increase in temperature of 40 mK above 1.9 K. This was a clear sign of the existence of an abnormal heat dissipation of $10.7 \pm 2.1 \text{ W}$, corresponding to a resistance of $180\text{--}260 \text{ n}\Omega$. (We now know, *a posteriori*, that we can use this “calorimetric” technique to detect these types of faults.) Had the resistance remained as small as this there would have been no major problem. However, because the current was ramped up to 8.7 kA on 19 September, localized heating increased the resistance, leading to thermal runaway. The heat dissipation was nearly 9 kW by the time the quench-detection threshold of 1 V was reached. Within a second, an electrical arc developed, puncturing the helium enclosure. This led to a release of helium into the insulation vacuum of the cryostat and the subsequent collateral damage described above.

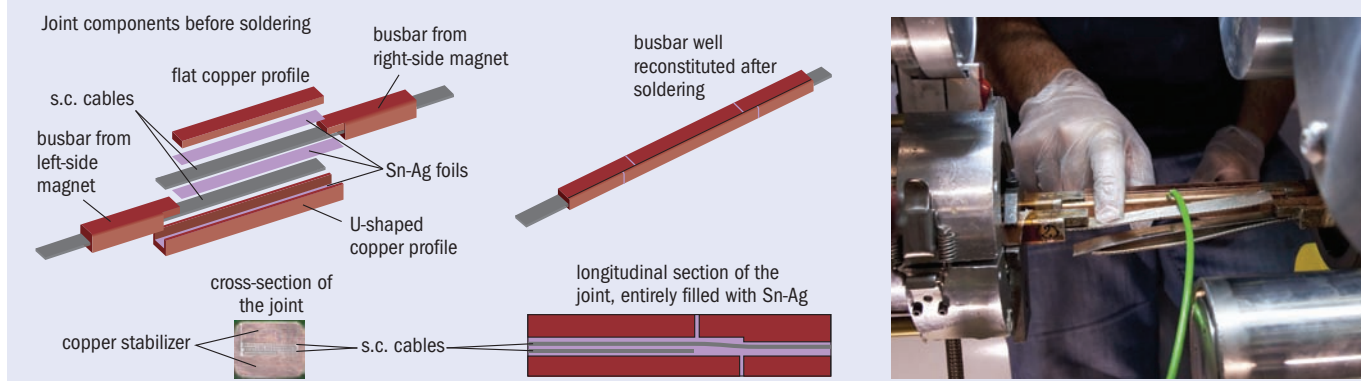
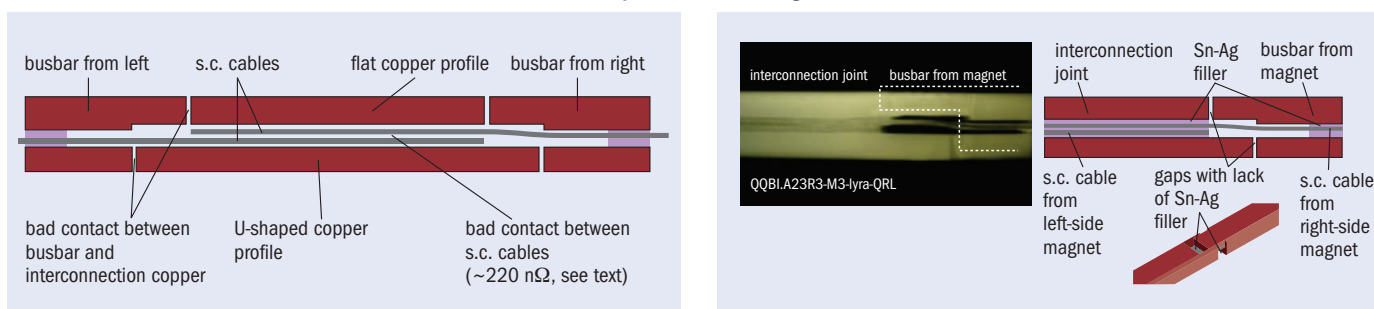

Fig. 2. Left: The various components of an interconnection. Right: A real interconnection, with as yet unconnected cables in the foreground. Note, there are two busbars in each interconnection sleeve, i.e. six 13 kA joints for each magnet interconnection.



Left: Fig. 3. Schematic of the defective joint assumed to have caused the incident in September 2008. Right: Fig. 4. A defective interconnection, with the superconducting cable detached from the stabilizer. In the gamma-ray photo, left, the two vertical gaps appear to be filled, but electrical measurement and visual inspection showed that they are in fact open, as indicated in the diagram. There is therefore no continuity in the stabilizer and current must flow in the isolated cable.

So what had happened? A thermoelectrical model was able to simulate the thermal runaway of the resistive zone in the splice at 8.7 kA, based on the hypothesis of a resistance of 220 nΩ together with a lack of contact between the superconducting cable and copper stabilizer at the joint, as well as the existence of a longitudinal gap in the stabilizer as in figure 3 (Verweij 2009). This discontinuity in the stabilizing copper is important because it impedes the sharing of current between cable and stabilizer. The time constant of the current decay in the busbar is 104 s and the copper there is designed to cope with the heat generated as the current decays in the whole circuit. By contrast, the copper matrix of the superconducting cable is of a size that is sufficient to withstand a discharge time in a resistive state of less than 1 s – the decay time for a single magnet. If there is a discontinuity in the copper stabilizer as well as no contact between the cable and stabilizer, the joint in the superconducting cable cannot sustain the 104 s-long discharge and it melts away.

A subtle enemy

Thus, while the incident was triggered by a bad splice – that is a bad superconductor-to-superconductor joint – the analysis revealed a more subtle possibility. Although the splice between superconducting cables may be good, the surrounding copper stabilizer may not be in contact with the cable, as shown in figure 4. In fact, if the stabilizer is in good contact with the superconducting cable and just has a short longitudinal gap – a few millimetres, say – there is no danger: in a quench of the joint the current can pass through the copper matrix of the superconducting cable and the small amount of heat

generated can escape easily via conduction in helium or the busbar.

However, if this gap is coupled with a lack of tin-silver soldering, i.e. the cable at the splice-to-busbar transition is not in good contact with the stabilizing copper for a certain length, then the situation can diverge. The current has to flow through the cable for the whole distance that the cable is isolated and the heat may become too large to escape before a large rise in temperature occurs, initiating thermal runaway and rapidly reaching the melting point in a few seconds. An interconnection joint can be quenched by external heating, for example by warm helium coming from a nearby quenching magnet. The lack of stabilizer continuity could thus cause thermal runaway in the busbar and it turns out to be a more subtle enemy than a bad splice, because it is more difficult to detect.

The task force that investigated the incident proposed a number of remedies, mitigation measures and points to study to improve safety and reliability of the LHC. These included the implementation of a new QDS on the busbars and interconnection line, with a sensitivity threshold of 0.3 mV during a ramp. In a steady state the new QDS can detect a bad splice with a resistance above 1 nΩ. Indeed, the worst interconnection splices have turned out to be about 3 nΩ, far below the runaway threshold, which is estimated to lie well above 50 nΩ.

Moreover, while hunting for bad interconnection splices in October 2008, we realized that the “old” QDS can be used in a measuring mode (rather than the usual active mode) to detect bad splices inside magnets that are in a superconducting state (i.e. at 1.9 K). Although not precise, these (and calorimetric) measurements quickly ▷

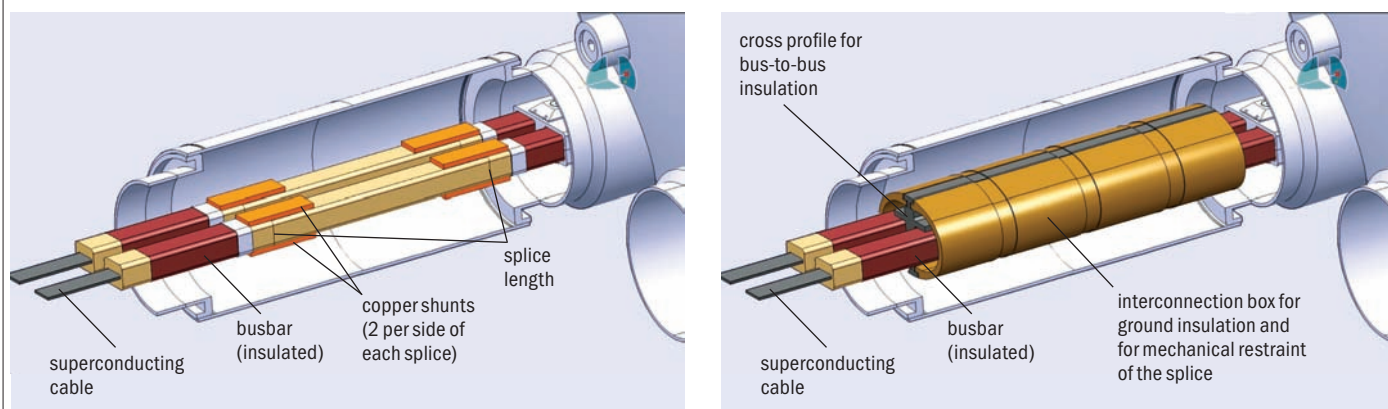

Fig. 5. Copper shunts on the splices soldered across the joints, left, will overcome possible problems with poor contacts between the superconducting cable and the copper stabilizer. They will be encased in a restraining box, right. (Courtesy P Fessia and H Prin.)

revealed three magnets (two in the LHC and one in reserve) with defective internal splices of 100, 50 and 25 n Ω . The two installed magnets were replaced, an action that meant that four sectors in total had to be warmed up during the shutdown in 2008–2009. More precise, dedicated tests that were made during the last months with the QDS system in measuring mode found no further bad internal splices, although the system did find 12 dipoles with an internal resistance well above the specification but below 25 n Ω . Internal splices are much less dangerous than interconnection splices because they are covered by the QDS of the magnets, where the current is cut off in less than 1 s. Moreover, all internal splices had been checked during cold-acceptance tests of the magnets at 8.6–9.0 T.

The danger of the lack of stabilizer continuity in the busbar required a separate diagnostic method. By measuring a busbar in its resistive state (i.e. warm) over a minimum length (two or three magnets, i.e. 30 or 45 m) one can infer if there is a zone or zones where the cable is not in contact with the stabilizer in conjunction with a gap in the stabilizer. So far this has been done for the four sectors that were warmed up during the long shutdown. In these, all of the bad joints where the defect was longer than 20–25 mm were fixed by resoldering. The other four sectors were measured at 80 K with much less accuracy. As a result one of these sectors was warmed up and three bad joints were repaired, although some defects of almost 40 mm remain, and will be fixed in future.

In the three sectors that were not warmed up, the inherent uncertainty in the cold measurements, means that defects up to 70 mm long have not been excluded. This limits the maximum safe current for powering the magnets with no risk of thermal runaway in the joints. Different studies based on different models have been made to evaluate the critical defect length, based on input from an experiment performed with a cable insulated from the busbar stabilizing copper for 50 mm. The results of these studies led to the decision to limit the field of the magnets to 4.5 T to begin with, and so allow commissioning with collisions at 3.5 TeV per beam, half of the maximum energy (Myers 2010). The LHC has been operating successfully in this manner since the end of March and will continue to do so throughout 2010 and 2011, allowing the experiments to gather significant amounts of data.

To exploit the full potential of the accelerator by pushing the magnets to 8.3 T, all bad interconnections with the cable detached from the stabilizer copper will have to be fixed. Experience with the sec-

tors that were raised to room temperature during the shutdown suggests that around 10–15% of the joints will need to be resoldered. In addition, we have devised a system that will stabilize all of the interconnections. This involves a relatively simple copper shunt that will be soldered across all of the 10 000 or so interconnections (figure 5). This shunt will definitely cure the issue of the possible lack of continuity of the stabilizer. The aim is to ensure the complete electrical stability of the superconducting magnet system for the LHC's foreseen lifetime of 25 years (Bertinelli *et al.* 2010). This will in turn allow the fullest possible returns in terms of new physics in a previously unexplored energy region.

● This article is based on the longer report, *Superconductivity: its role, its success and its setbacks in the Large Hadron Collider of CERN* (Rossi 2010).

Further reading

- M Bajko *et al.* 2009 *LHC Project Report* **1168**.
- F Bertinelli *et al.* 2010 IPAC '10, CERN-ATS-2010-144.
- S Myers 2010 IPAC '10, CERN-ATS-2010-123.
- L Rossi 2010 *Supercond. Sci. Technol.* **23** 034001.
- AP Verweij 2009 *Proc. 2009 Chamonix Workshop on LHC Performance*, CERN-ATS-2009-001.

Résumé

Les subtilités de la supraconductivité

En septembre 2008, un incident sérieux interrompait le fonctionnement du LHC. Il est vite apparu qu'une seule défaillance dans une connexion électrique entre deux aimants voisins en était la cause. Un raccord défectueux avait en effet créé une petite zone résistive dans un jeu de barres supraconductrices. Il s'agissait d'une défaillance limitée dans un système relativement simple sur le plan technique, mais elle a eu des conséquences dramatiques du fait des subtilités de la supraconductivité. L'analyse de la panne a également mis en évidence un autre événement : un claquage thermique dû au manque de continuité dans le stabilisateur en cuivre du jeu de barres. Il s'agissait là d'un ennemi plus difficile à cerner, mais il a également été vaincu, comme l'explique Lucio Rossi.

Lucio Rossi, CERN.

FACES AND PLACES

CELEBRATION

90-50-10: BNL marks special anniversaries

Brookhaven National Laboratory celebrated a trio of important anniversaries on 10–11 June as part of the annual Relativistic Heavy Ion Collider (RHIC) and Alternating Gradient Synchrotron (AGS) users' meeting. Dubbed "90-50-10", the celebration recognized the 90th birthday of Ernest Courant – one of four accelerator pioneers who originated the idea of strong focusing – together with the 50th anniversary of the start-up of the AGS and the 10th anniversary of operations at RHIC. More than 20 leading scientists, including two Nobel laureates honoured for work at Brookhaven, took the stage with stories of the early days, fierce international competition and building equipment with their bare hands.

"When I got here, it looked like an army camp, filled with barracks," said Courant, who first visited Brookhaven in 1947. The following year, he joined the laboratory "for good" as a member of the team that was assembling Brookhaven's first accelerator, the Cosmotron. This proton synchrotron was the first machine to send particles to giga-electron-volt energies. In 1952, as Courant recalled, word of Brookhaven's success travelled quickly after reaching the world record of 1.3 GeV – almost five times higher energy than had ever been achieved previously.

It particularly interested European physicists who wanted to build a similar, but larger, machine at CERN. They formed a study group with the Brookhaven team to figure out how it could be done; building an accelerator 10 times more powerful than the Cosmotron with existing technology would have required 100 times more steel, resulting in a 200 000-tonne machine. It was at one of these meetings that Courant, M Stanley Livingston and Hartland Snyder presented the solution of strong, or alternate-gradient, focusing. (This idea was first conceived in 1949 by Nicolas Christofilos, who later worked briefly at Brookhaven. Unaware of the work of Christofilos, the Brookhaven team independently developed strong focusing three years later.) CERN went on to implement this scheme in the Proton Synchrotron, while Brookhaven applied it in the AGS.

Nobel laureate James Cronin spoke of his



Ernest Courant and Brookhaven director, Sam Aronson. The yellow tie draped around Courant's neck contains a reproduction of TD Lee's and C N Yang's notes on parity-violation.

experiences at Brookhaven, the first time as a research associate at the Cosmotron. "I want to stress that Brookhaven for me was an extraordinary experience, not only because of what I learnt and did in my own physics, but because of all of the people who surrounded me," he said. "I was so lucky to have this experience of interacting with these high-class, smart people going after problems that could be solved with simple, short experiments. That gets into your culture." Later, as a visiting scientist from Princeton, Cronin, together with Val Fitch and colleagues, discovered CP-violation in K^0 decays at the AGS, where they had set up a detector built mostly by hand. The experiment ran for only one week in 1964, but earned Cronin and Fitch the Nobel prize in 1980.

Samuel Ting, who shared the 1976 Nobel Prize in Physics for the discovery of the J/Ψ particle with Burt Richter, talked about his experience with precision experiments on the ground, and most recently, in space. He said that in his career of some 40 years one of his most difficult tasks was acquiring the five tonnes of soap (along with 100 tonnes of lead and five tonnes of uranium) needed for AGS Experiment 598, the study that eventually revealed the J/Ψ particle. Ting is now working on a different challenge: sending the Alpha Magnetic Spectrometer (AMS) into space. Backed by institutions from 16 countries



Derek Lowenstein (left) receiving the appreciation award from DOE associate director of science for high-energy physics, Dennis Kovar. (Photos courtesy Brookhaven National Laboratory.)

(and about 600 scientists), AMS will measure high-energy charged cosmic rays in the search for antimatter, dark matter and other mysteries of the universe.

Looking to the future of accelerators at Brookhaven, Thomas Roser, collider-accelerator department chair, described how stochastic cooling will increase luminosity at RHIC by almost an order of magnitude. Steve Vigdor, associate laboratory director for nuclear and particle physics, explained that this increased luminosity, coupled with detector upgrades, will permit researchers to quantify the properties of the quark-gluon plasma, search for the "critical point" and study local symmetry violations. Vigdor also described Brookhaven's longer-term plans to add an electron ring to RHIC for the study of electron-ion and electron-polarized proton collisions.

At a celebratory dinner, former AGS and later collider-accelerator department chair, Derek Lowenstein, was presented with an Appreciation Award from the US Department of Energy (DOE). Dennis Kovar, the DOE associate director of science for high-energy physics, commended Lowenstein for his "outstanding leadership and service" as chair for 27 years.

● Based on an article for *The Bulletin*, by Kendra Snyder. For videos of the more than 20 talks, see www.bnl.gov/905010.

LABORATORIES

Tunnel boring for European XFEL begins

On 7 July the first tunnel-boring machine for the European XFEL started drilling the tunnels for the X-ray laser that will extend for 3.4 km from Schenefeld in north Germany to the site of the DESY laboratory in Hamburg. It will take the machine about a year to excavate two of the photon tunnels plus the main tunnel for the superconducting linear accelerator. It will be joined in late 2010 by a second, smaller machine that will excavate the other sections of the photon-tunnel system.

Before the machine powered up, on 30 June a “tunnel fest” to honour an old custom took place on the site of the future research campus of the European XFEL in Schenefeld. Like mining, tunnel construction in Germany follows a special tradition that still plays an important role for miners and tunnel builders. The tunnel and boring machine were “christened” by their respective patronesses – the tunnel now bears the first name of Hamburg’s state minister for science, Herlind Gundelach, and the machine is called “TULA”, short for “Tunnel for Laser”. The ceremony also featured the blessing of a statue of St Barbara, the patron saint of tunnel works, who is said to protect workers from the dangers connected with their labour.

Around 560 guests from science and politics gathered for the ceremony, which was accompanied in proper style by a miners’ choir. As Massimo Altarelli, managing director of European XFEL GmbH, underlined

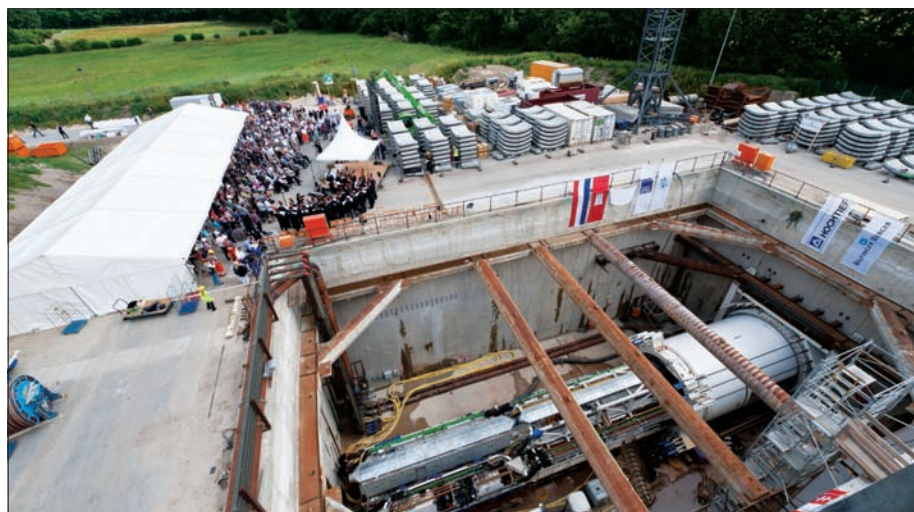

With a diameter of 6.17 m, a length of 71 m and a weight of 550 tonnes, the first tunnel-boring machine for the European XFEL commenced drilling operations on 7 June. (Photos courtesy European XFEL.)

in his welcome address, the occasion celebrated: “A double milestone on the road to the European XFEL. First of all, it marked the overall start of tunnel construction. In addition, this is the first time such a ceremony has taken place under the banner of European XFEL GmbH, the new international research facility that will build and operate the European XFEL. The facility has established itself almost unnoticed in northern Germany in recent months, and today marked its first real public debut.” The European XFEL is due to be switched on in 2014.



The patron saint of tunnel works, St Barbara, takes her place to protect workers from danger.

COLLABORATION

South Africa joins the ATLAS experiment

The ATLAS collaboration has increased its reach across Africa now that South Africa has joined Morocco as the second member country from that continent. This development follows a unanimous ballot at the meeting of the ATLAS collaboration board in Copenhagen on 2 July.

South Africa’s contributions to high-energy particle physics began with physicists of South African origin who worked abroad, such as Stanley Mandelstam, well known for this work on the kinematics of particle interactions. The first observation of the

neutrino in cosmic rays occurred in the 1960s in the ERPM gold mine near Boksburg after Friedel Sellschop alerted Fred Reines to this opportunity and then led the South African component of the research team.

South African collaboration at CERN started initially with participation in the NA43, NA59 and NA63 experiments and at the ISOLDE facility. CERN and South Africa then signed a co-operation agreement in 1992. The contributions of theorist Jean Cleymans to the statistical model of particle production

in heavy-ion collisions led to South African participation in the ALICE experiment at the LHC from November 2001. CERN’s John Ellis further encouraged the development of the co-operation with CERN.

The participation in ATLAS was initiated by the head of the South African iThemba Laboratory of Accelerator Based Sciences, Zebulon Vilakazi, who introduced Keteivi Assamagan of Brookhaven National Laboratory to South Africa. This led to the establishment of a new high-energy-physics

group at the University of Johannesburg under Simon Connell, which is aligned with Assamagan's work in the muon-detector subsystem and on the Higgs and supersymmetry sectors. The new group was at first hosted within ATLAS by Brookhaven. At the same time, Peter Jenni, initially as ATLAS spokesperson, worked actively to develop and guide the process of the South African involvement in ATLAS over several years of discussions at both university and government level.

An important step in developing high-energy physics in South Africa was to unify all of the CERN-based activities



South Africa joins Morocco as the second African nation to be involved as a member country.

into one coherent network, known as the SA-CERN Programme (ATLAS, ALICE, ISOLDE and theory). This network worked together

on issues of Grid development, student training, schools planning, interaction with government and by applying jointly for support at a national level.

The programme has also attracted additional people to South Africa. Trevor Vickey moved recently to the University of the Witwatersrand and formed an experimental high-energy-physics group to work within ATLAS on the Semiconductor Tracker and various physics studies. The expression of interest to join ATLAS was made jointly by the Universities of Johannesburg and the Witwatersrand; the University of Cape Town will join soon.

CELEBRATION

CERN marks Lyn Evans' retirement in style

After 41 years at CERN, Lyn Evans has officially retired. For 30 of these years, Evans has been involved in one way or another with the LHC – as it has grown from the first designs in the early 1980s to become reality as the world's highest-energy particle collider, with the first results presented at this year's main summer conference (p5).

Evans came to CERN in 1969 as fellow in the Linac Group, moving to the 300 GeV project that would become the Super Proton Synchrotron (SPS), soon after its approval. He went on to become heavily involved in the operation of the SPS as a proton-antiproton collider, which led to the discovery of the W and Z bosons at CERN and the award of the Nobel prize in physics to Carlo Rubbia and Simon van der Meer. From 1994 he led the LHC Project until the machine started up with first beam in September 2008.

In his time at CERN, Evans worked under a total of 10 directors-general, six of them during the LHC era. All of these six contributed, either in person or by video link, to a special colloquium, "The Large Hadron Collider – from Inception to Operation", which took place at CERN on 15 June to honour Evans on his retirement.

Herwig Schopper (1981–1988) began by recalling the Large Electron-Positron (LEP) collider as "the cradle of the LHC". The size of LEP became the size of the LHC, and the earlier collider gave birth also to a new era in experiments at CERN. With external finance playing an important role, the experiments



Lyn Evans receives a standing ovation at the end of the colloquium to mark his retirement.

became like institutes, involving the international community, especially after the US government abandoned the project for the Superconducting Super Collider.

Carlo Rubbia (1989–1993) joined in by video, offering a memory of when the SPS became the world's first proton-antiproton collider at 4.15 a.m. on 9 July 1981 – an event witnessed only by Rubbia, Evans and Sergio Cittolin in the SPS control room. In his talk that followed those of the directors-general, Evans noted Rubbia's seminal role. "Without the proton-antiproton collider we would not have known how to build the LHC," he said.

The LHC passed from a dream to a fully approved project under Chris Llewellyn Smith (1994–1998), who contributed by video

link. In 1996, CERN Council agreed to the construction of the LHC in a single phase, thanks to the contribution of non-member states. In his appreciation of Evans, Llewellyn Smith noted his great help in working with these countries.

Luciano Maiani (1999–2003), also by video, recalled the "agitated times" during his mandate as director-general. These included the closure of LEP, just when there seemed to be some hints of the long-sought Higgs particle, and the rise in costs of the LHC. There were also happier times, with the main magnet production by industry getting into full swing.

Installation of the LHC was finally completed under Robert Aymar (2004–2008), who was

also able to see the first beams pass round the new machine and host the official inauguration in October 2008. Aymar had been chair of the External Review Committee in 1993 that was mandated by CERN Council to evaluate the LHC project. As director-general he oversaw the resolution of the financial difficulties

Rolf Heuer, the current director-general, had the privilege of presenting the recent successes of the LHC, as the experiments rediscover the “Standard Model zoo” and beam commissioning continues at full speed. He then handed the floor to Evans, who spoke fondly about his time at CERN, delighting the audience with his memories of good times and bad.



Lucio Rossi (right) presents Lyn Evans with the “Lyn Hadron Collider”.

The colloquium ended with a standing ovation for Evans – and two surprises. One

was a small model of an LHC dipole, signed by the six directors-general and named the “Lyn Hadron Collider”. The other, by video, was a live performance by the Morryston Orpheus Choir from Swansea, who had blessed the LHC with song in the CERN Control Centre on 12 October 2008. They finished with the Welsh national anthem. It was a proud moment for the man who, commenting in an interview with the BBC that he had travelled a lot for the LHC, recalled how on meeting the president of China, he thought to himself, “not bad for bloke from Aberdare”.

● For all of the presentations, see <http://indico.cern.ch/conferenceDisplay.py?confId=93701>.

WORKSHOPS

COMPASS turns to new round of QCD studies

The COMPASS collaboration has recently submitted the COMPASS-II proposal to the CERN SPS committee. The aim is to explore several new and interesting aspects of QCD through a whole series of measurements with the versatile COMPASS apparatus.

As one part of the proposal, COMPASS plans to study generalized parton distributions (GPDs) by scattering the highly polarized M2 muon beam off a liquid-hydrogen target surrounded by a recoil detector. The experiment will access as yet uncharted territory between the gluon-dominated region of small Bjorken- x measured by H1 and ZEUS at HERA and the valence-quark-dominated region at large Bjorken- x , which was accessed by HERMES at HERA and at Jefferson Lab. The focus of the GPD programme in the COMPASS-II proposal is the study of the GPD H. This distribution describes interactions in which the helicities of both the struck parton and the nucleon are conserved. Access to H at COMPASS will be provided by the deeply virtual Compton scattering (DVCS) process off unpolarized protons. The same data will make possible the mapping of the transverse position of partons with respect to the fraction of the nucleon longitudinal momentum that they carry. Such a mapping is sometimes referred to as “nucleon tomography”.

As another part of the proposal, COMPASS plans to scatter pions from the M2 beam line off the existing polarized ammonia target,

using an absorber. COMPASS will thereby become the first “polarized” Drell-Yan (DY) experiment to access transverse-momentum-dependent parton distributions (TMDs). Among the distributions to be studied are the Sivers, Boer-Mulders and “pretzelosity” TMDs as well as transversely polarized quark distributions. Examination of the Wilson-line structure of final-state interactions in QCD predicted that the Sivers function should have opposite signs in DY and semi-inclusive DIS (SIDIS) processes. Groups from several laboratories intend to be first to confirm this “restricted universality”, which is rooted in fundamental aspects of QCD.

In addition, the proposal shows how new insights into QCD at low energies will be gained by measurements of exclusive final states produced by incoming high-energy pions at very small momentum-transfer to the recoiling nucleus – that is, in the Primakoff region.

To strengthen the first two of these physics opportunities, the COMPASS collaboration organized two international workshops at CERN in spring 2010. The workshops considered both the theoretical and experimental scenes, including plans for studies at other laboratories around the world.

The first workshop, “GPDs@COMPASS”, concentrated mainly on theoretical aspects after starting with experimental reviews, including a look at existing DVCS measurements. Etienne Burtin of Saclay presented the outlook for COMPASS-II and

underlined that no measurements exist of the specific kinematic domain that COMPASS will access. Matthias Burkardt from New Mexico State University set the theoretical scene by presenting GPDs as an indispensable tool for studying the structure of the nucleon. He also stressed the importance of a (later) continuation of the GPD programme using a transversely polarized proton target to access the GPD E at COMPASS kinematics. Extractions of H and E at similar kinematics are the only known way to determine the total angular momentum of quarks in the nucleon via Ji’s sum rule – a long-term goal of the GPD community. The spatial structure of the nucleon transverse to the direction of motion of particles in the beam will be measured at COMPASS for the region 0.01–0.1 in Bjorken- x , and this will be of special interest for the Monte Carlo simulation of backgrounds at the LHC.

Other topics that were discussed include: nucleon structure from a phenomenological viewpoint; the first promising attempts on global GPD fits; experience building a phenomenological GPD model to describe exclusive vector-meson production data; and, as a complementary approach to determine moments of GPDs, the state of the art in QCD calculations on a Euclidean lattice. The one-day workshop was summarized by Andreas Schäfer of Regensburg, who concluded that for understanding non-collinear QCD – a major task that requires

progress on different research fronts – GPDs are the only known rigorous and undisputed approach. “They do not answer all questions,” he said, “but most questions cannot be answered without them.”

The second workshop, “Studying the hadron structure in Drell-Yan reactions”, covered two days. It opened with reviews of theoretical and experimental progress in the field. In his talk, Daniel Boer of Groningen underlined that measurements of TMDs in DY processes are well suited for the study of 3D aspects of nucleon structure. Paul Reimer of Argonne covered four decades of fixed target and collider DY experiments, including the first observation of TMD-induced effects in the violation of the Lam-Tung relation.

The first day then continued with a focus on theoretical topics, including recent calculations of higher-order QCD corrections for the DY process. Relevant aspects of the formalism of TMDs and TMD phenomenology in DY were discussed and the complementary nature of DY and SIDIS measurements in accessing the underlying physical distributions was highlighted. The day concluded with a round-table covering TMD models and GPD studies in DY processes. The second day saw reviews on all DY measurements planned at world-leading laboratories such as Fermilab, Brookhaven, J-PARC, GSI, JINR and CERN. The huge variety of proposals reflects the strong interest of the community in DY studies, a main focus being the study of spin-dependent effects in DY reactions using polarized beams and/or targets. With COMPASS-II, CERN would have a great opportunity to play a leading role.

In summary, these two workshops successfully strengthened the physics goals of the COMPASS-II proposal, in particular the necessity of new measurements in the kinematic region that is accessible only to COMPASS at CERN.

- The programme details and all of the presentations at the two workshops are available on the web. For GPDs@COMPASS see <http://indico.cern.ch/conferenceDisplay.py?confId=77527>; for Studying the hadron structure in Drell-Yan reactions see <http://indico.cern.ch/conferenceDisplay.py?confId=85721>.

Further reading

COMPASS II Proposal 2010
CERN-SPSC-2010-014/SPSC-P-340.

VISITS



On 13 July **Nickolay Mladenov**, Bulgarian minister of foreign affairs, left, visited CERN. He toured the CMS control centre with **Guido Tonelli**, right, CMS spokesperson, after receiving a general introduction to CERN's activities from Rolf Heuer, CERN's director general.

NEW PRODUCTS

Elma Electronic Systems has released a new two-slot VPX/OpenVPX test and development platform that accommodates both 3U and 6U boards via a shelf divider. This E-Frame Series test platform can connect multiple backplanes and enables developers to power up one or more VPX blades under test and interconnect the J1 fabric connections to emulate an application. The platform allows easy cable access to components on either side of the board under test. For more details, contact Valerie Andrew on +1 510 656 3400; e-mail sales@elma.com; or see www.elma.com.

Hidden Analytical Ltd has announced the extension of the HPR-20 Series of gas analysers with the addition of an expanded range of gas-stream selectors. Standard selector options give the choice of 8, 20, 40 and 80 channels for application to multiple gas-stream control and monitoring in the pressure regime from 10 mbar to 10 bar. Stream selection is fast with switching times of less than 1 s. For more details, tel +44 1925 445 225; or e-mail info@hidden.co.uk.

MKS Instruments Inc has introduced the High Cycle Valve, a small, light and durable vacuum valve rated for 10 000 000 cycles. A new formed stainless-steel bellows prevents outgassing, virtual leaks and particle entrapment, ensuring easy maintenance and extending the cycle life of the valve.

High-flow port sizes use maximum internal diameters for greater conductance. For more details, contact Mary Ann Naddy on +1 978 645 5538; fax +1 978 557 5100; e-mail MaryAnn_Naddy@mksinst.com; or visit www.mksinst.com.

Pfeiffer Vacuum has announced HiPace M, a new series of magnetically levitated turbopumps for pumping speeds of 300, 700 and 800 l/s and high compression ratios for all gases. The pumps are characterized by their high flexibility in all installation orientations, while a special rotor design affords dependable operation. The low dynamic magnetic field does not interfere with nearby equipment. For more details, contact Sabine Neubrand-Trylat on +49 6441 802 169, fax +49 6441 802 500; e-mail Sabine-Neubrand@pfeiffer-vacuum.de; or see www.pfeiffer-vacuum.net.

Trek Inc has introduced its 2200 Series of 40 W high-voltage amplifiers. Three initial models, 2205, 2210 and 2220, provide output voltage ranges of ± 500 V, ± 1 kV and ± 2 kV, respectively. The series also includes features such as DC stability and wide bandwidth, well regulated and controlled AC-output signals, DC-offset adjustment with front panel metering and auto-recovery shutdown for output-overpowering protection. For more details, tel +1 585 798 3140; e-mail sales@trekinc.com; or see www.trekinc.com.

COMMUNICATION

SPARC Europe gives CERN an award for open access

SPARC Europe has presented its 5th Award for Outstanding Achievements in Scholarly Communications to CERN for its comprehensive approach to open access, especially with regard to the SCOAP³ project – the Sponsoring Consortium for Open-Access Publishing. Salvatore Mele received the award on behalf of CERN during the LIBER annual conference in Aarhus.

SPARC Europe is an alliance of more than 100 European research libraries, library organizations and research institutions. It aims to provide a voice for the community and the support and tools it needs to bring positive changes to the system of

scholarly communications.

The award to CERN recognizes that the organization has passed several milestones in its open-access-publication policy: in 2003 a policy document was issued to reinforce self-archiving by researchers; in 2004 CERN signed the Berlin Declaration; and in 2005 CERN's policy on open access was approved, requiring researchers to deposit a copy of their published articles in an open-access repository and encouraging them to publish in open-access journals. CERN launched the SCOAP³ project in 2007, which aims to aid open-access publishing in high-energy physics by re-directing subscription money.



Salvatore Mele, right, received the award on behalf of CERN, from Bas Savenije, chair of SPARC Europe. (Courtesy Henrik Storgaard Sørensen.)

UK honours for services to science

Brian Cox of Manchester University is to become an officer of the Order of the British Empire (OBE) for services to science, as announced in the Queen's Birthday Honours list for 2010. Cox, a particle physicist, most recently with the ATLAS collaboration, has become well known as a presenter of television and radio programmes about science.

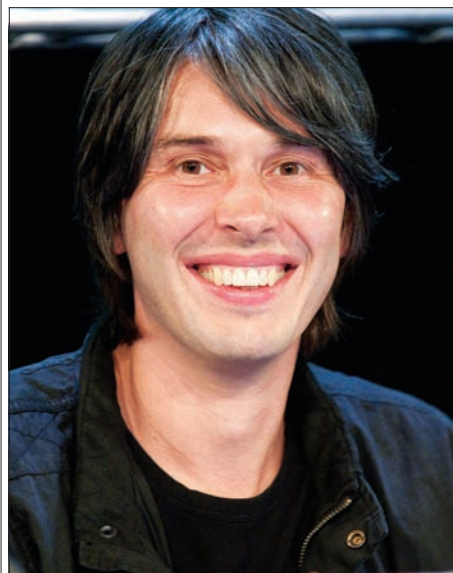

Brian Cox, OBE. (Courtesy Jesse Karjalainen.)

Also named is Jerry Cowhig, the managing director of IOP Publishing, publishers of the *CERN Courier*, among other titles. Cowhig, who will be made member of the British Empire (MBE), has been managing director of IOP Publishing for 15 years, presiding over a major expansion of the firm's international activities. Like Cox, Cowhig is honoured for his services to science.



Jerry Cowhig, MBE. (Courtesy IOP Publishing.)

APS opens access to LHC articles

On 6 July, the American Physical Society (APS) and CERN announced that initial experimental results from the LHC published in *Physical Review Letters* and *Physical Review* will be made available open access and under a Creative Commons licence, for all interested parties to read and reuse. With this gesture, the APS and CERN "acknowledged the fundamental significance of the work being performed by these large international collaborations".

First to appear under this agreement is a paper from the CMS collaboration, with results on transverse-momentum and pseudorapidity distributions of charged hadrons in proton-proton collisions at 7 TeV centre-of-mass energy (Khachatryan et al. 2010). The results indicate an increase in the number of charged particles per unit pseudorapidity that exceeds the predictions of the commonly-used event simulation models.

Further reading

For the APS announcement, see <http://prl.aps.org/edannounce/2010-APS-CERN-LHC>. V Khachatryan et al. (CMS collaboration) 2010 *Phys. Rev. Lett.* **105** 022002.

OBITUARIES

Georgy Leksin 1929–2010

Georgy Leksin, a well known experimental particle and nuclear physicist at the Institute for Theoretical and Experimental Physics (ITEP) in Moscow, passed away on 27 June.

Georgy was born in Moscow on 24 December 1929. He graduated from the Physics Department of Moscow State University and followed this with a PhD at JINR on proton-deuteron backward scattering, before moving to ITEP in 1957. His interests covered a range of questions, from the development of the spark-chamber technique, through π - π scattering and polar diagrams in nuclear physics, to particle interactions inside nuclear matter.

Georgy led experimental studies of inelastic nuclear interactions that were carried out in research centres around the world, including ITEP, JINR, the Institute of High Energy Physics (Protvino), Yerevan, CERN, Fermilab and DESY. This research showed that the spectra

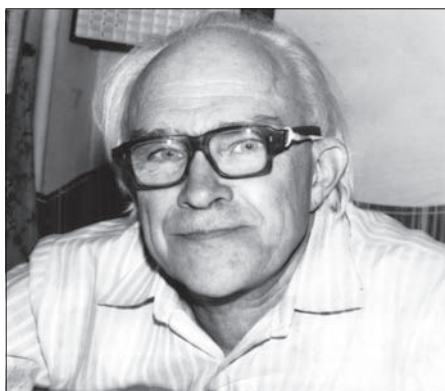

Georgy Leksin. (Courtesy ITEP.)

of hadrons (proton, pions, kaons) emitted in high-energy nuclear reactions outside the kinematical region of quasi-nucleon interactions do not depend on the energy of the incident particle and its type (protons, pions, kaons, photons, neutrinos) or on the

atomic number of the target nucleus. The most popular explanation for this phenomenon was through the interaction of incident high-energy particles with dense droplets inside nuclei (like heavy multi-quark bags).

Being a scientifically motivated person, Georgy educated in his group many top-level physicists who now work in research laboratories all over the world. He was one of the founders of the ITEP Winter Physics School, which has attracted young talented scientists for more than 35 years.

He was also greatly interested in various aspects of culture, especially in painting, architecture and history – an interest that he transferred to many of his colleagues. All those who had the pleasure of meeting Georgy will remember him as a wonderful person.

Alexander Arefyev, Mikhail Danilov, Vladimir Gavrilov and Yuri Zaitsev, ITEP.

Gilles Sauvage 1939–2010

Gilles Sauvage, a physicist from LAPP-Anecy working with ATLAS, passed away on 21 April.

Gilles Sauvage was deeply involved in many generations of experiments at CERN as he followed the evolution of the field at the energy frontier. He started with the group from Laboratoire de l'Accélérateur Linéaire, Orsay, working in the WA2 hyperon experiment at the Super Proton Synchrotron (SPS), from 1976 to 1979. With the same group he became a founding member of the UA2 collaboration at the SPS $p\bar{p}$ Collider, in which he was active throughout the duration of the experiment. He then moved to the Laboratoire d'Anecy-Le-Vieux de Physique des Particules (LAPP) in 1986 and joined first the L3 group at the Large Electron-Positron collider, making important contributions to the construction, calibration, installation and commissioning of the BGO crystal calorimeter. Later, in the mid-1990s, Gilles joined ATLAS and led the LAPP-Anecy group through the intense period of the construction at LAPP of one third of the modules for the ATLAS liquid-argon barrel electromagnetic calorimeter. He then



Gilles Sauvage. (Courtesy LAPP.)

followed “hands-on” its integration and installation at CERN. He retired in 2006, but his passion for physics motivated him to remain fully active until the last day.

For those of us who worked with him in designing, constructing and testing the liquid-argon electromagnetic barrel calorimeter, Gilles was rather like our living encyclopedia. We often asked him about the finest details on how the calorimeter was built and assembled. While the modules were being built at LAPP, Gilles was with them day

and night, and he led their assembly into two half-barrel cylinders as well as the insertion into the cryostat.

Gilles was an exceptional experimentalist, who also set high standards in how to work with great human qualities in a large collaboration. He always sought the most elegant technical and scientific solutions, and would not accept easy short-cuts. He never acted as a “big boss”, but instead motivated junior and senior colleagues by setting the example of working hard on the floor over many years.

Having coffee with Gilles was always a great pleasure, as he would remember a story of his past experiments – little anecdotes that only he knew. He was also poetic, often referring to flowers, birds and treks in the mountains. And when Gilles described his garden it was like being there and seeing every plant grow, tasting every fruit.

It is hard to imagine how to continue without him. Our thoughts and sympathy go to his family and close friends.

Colleagues and friends from ATLAS.

RECRUITMENT

For advertising enquiries, contact *CERN Courier* recruitment/classified, IOP Publishing, Dirac House, Temple Back, Bristol BS1 6BE, UK.
Tel +44 (0)117 930 1264 Fax +44 (0)117 930 1178 E-mail sales@cerncourier.com
Please contact us for information about rates, colour options, publication dates and deadlines.

RUPRECHT-KARLS-
UNIVERSITÄT
HEIDELBERG



The Department of Physics and Astronomy of the Ruprecht-Karls-University in Heidelberg invites applications to fill - at the earliest possible date - the faculty position of a

Professor (W3) in Experimental Physics

The successful candidate is expected to play a leading role in future experiments to uncover fundamental particle physics mechanisms in the early universe, in particular to develop an improved understanding of interactions and particle properties driving structure formation. The position will complement existing Heidelberg groups performing research at the Large-Hadron-Collider (LHC) and in astrophysics to provide an alternative experimental access to the scientific quests described. A good integration in the local Heidelberg research infrastructure, the Graduate School for Fundamental Physics and a close cooperation with groups at the Max-Planck-Institute for Nuclear Physics will be essential. The vacant position corresponds to a full professorship and is expected to play a key role in shaping the future development of the field. Possible areas of research include: neutrino physics, dark matter searches and space base particle physics.

The successful candidate is expected to demonstrate a commitment to teaching in physics at both the undergraduate and graduate level and to participate in the self-administration of the University. Applicants for this W3-professorship are expected to have a Ph.D in physics and an excellent research record.

Prerequisites for application are a university degree and (in accordance with Article 47, paragraph 2 of the Higher Education Law of the State of Baden-Württemberg), a Habilitation, a successfully evaluated junior professorship or equivalent qualification.

The Ruprecht-Karls University in Heidelberg seeks to increase the proportion of female faculty and, for this reason, especially welcomes applications from women. Handicapped persons with the same qualifications will be given preference.

Qualified candidates are invited to submit their application until **30th September 2010** with the usual documents and a research plan to the **Dean, Department of Physics and Astronomy, Albert-Ueberle-Str. 3-5, D-69120 Heidelberg, Germany.**



THE UNIVERSITY OF
CHICAGO

The Department of Physics and the Enrico Fermi Institute at the University of Chicago invite applications for two tenure-track positions: one in experimental elementary particle physics with an emphasis on neutrino and non-accelerator physics, and one in experimental particle astrophysics and cosmology. The appointments will start in the Fall of 2011.

Successful candidates must have a doctoral degree in physics or a related field, a record of excellence in research, and are expected to contribute effectively to the Department's undergraduate and graduate teaching programs while engaging in forefront research. The appointments are expected to be at the level of Assistant Professor; however, an Associate or Full Professor appointment is possible for exceptionally well qualified candidates.

Applicants must apply online at The University of Chicago academic jobs website, <http://tinyurl.com/2011EFI-search> and upload a cover letter, curriculum vitae with a list of publications, and a brief research statement. The cover letter should be addressed to either Professor Ed Blucher, Chair, Experimental Elementary Particle Physics Search Committee, or to Professor Bruce Winstein, Chair, Experimental Particle Astrophysics Search Committee, depending on the discipline of interest. In addition, three reference letters will be required. (Referral letter submission information will be provided during the application process.)

Review of applications will start in the fall of 2010 and will continue until the positions are filled. To ensure full consideration, applications and recommendation letters should be received no later than November 1, 2010.

The University of Chicago is an Affirmative Action / Equal Opportunity Employer.

Jefferson Lab

Thomas Jefferson National Accelerator

is a U.S. Department of Energy, Office of Science laboratory that has a central and unique role in the field of nuclear physics, both in the U.S. and worldwide. Jefferson Lab's present and future program is as a world leader in hadronic physics and superconducting accelerator technologies. The primary nuclear physics facility is the Continuous Electron Beam Accelerator Facility currently operating at 6 GeV and being upgraded to 12 GeV. The laboratory has an international user community numbering approximately 1,300 physicists. Jefferson Lab is currently seeking outstanding individuals to fill three senior leadership positions.

Associate Director for Experimental Nuclear Physics

The Associate Director for Experimental Nuclear Physics is responsible for the execution of the experimental nuclear physics program. Responsibilities include the management of the Experimental Physics Division of approximately 140 staff, including 85 scientists and engineers. The division is responsible for the experimental nuclear physics program including the management of the experimental operations schedule for the program

in conjunction with the accelerator division and matched to the available resources.

The Associate Director participates in strategic planning, policy formation, budgeting, and science initiatives. The Associate Director represents the laboratory with government agencies, the international physics community, other laboratories, universities, as well as stakeholders.

The successful candidate will be a distinguished scientist with a proven record of physics research leadership and publication in nuclear physics or a related field. The candidate will have demonstrated leadership, communication skills, ability to manage resources, personnel, and technical knowledge relevant to accelerator-based experimental nuclear physics. A Ph.D. and substantial history of relevant experience in Nuclear Physics or related field, including increasing responsibility in nuclear physics research projects are required. The candidate will also have proven negotiation and interpersonal skills to develop and maintain excellent relations with internal and external stakeholders.

Deputy Associate Director Experimental Nuclear Physics

The Deputy Associate Director participates in all aspects of the management of the Experimental Nuclear Physics Division and reports to the Associate Director. The Physics Division has primary responsibility for the operation and continuous upgrading of the Jefferson Lab nuclear physics experimental



The Paul Scherrer Institute is with 1300 employees the largest research centre for the natural and engineering sciences in Switzerland and a worldwide leading user laboratory. Its research activities are concentrated on the three main topics structure of matter, energy and environmental research as well as human health.

The activities of the PSI Laboratory for Particle Physics focus on projects in theoretical physics, in high energy physics within the CMS experiment at the LHC, and in low energy precision physics at PSI's own world-leading facilities for pions, muons and ultracold neutrons, see ltp.web.psi.ch.

We invite applications for the newly established

Postdoctoral Fellowship for Excellence in Particle Physics

The named postdoc position is accompanied by a competitive salary and open to both experimental and theoretical physicists. Candidates are selected based on the strengths of their academic and research accomplishments and plans. Research activities proposed by the candidates should be in line with the program of the Laboratory for Particle Physics. Applicants must hold a doctoral or PhD degree in physics. You are welcome to contact the group leaders of the research groups to discuss your ideas prior to application. The successful candidate will join one of the laboratory's groups. In the future, this prestigious position will be advertised and filled every two years

For further information please contact: Prof Dr Klaus Kirch, phone +41 56 310 23 78, klaus.kirch@psi.ch
Please submit your application at the latest until October 30th, 2010 (including CV, list of publications, statement of research interests and addresses of at least three referees) quoting the ref. code by e-mail to thomas.erb@psi.ch or to Paul Scherrer Institut, Human Resources, ref. code 3200, Thomas Erb, 5232 Villigen PSI, Switzerland.
www.psi.ch



The University of Potsdam, institute of physics and astronomy in a joint appointment with the Deutsche Elektronen-Synchrotron DESY (post Zeuthen) invites applications for the position as

Head of DESY site Zeuthen in conjunction with a Full Professorship (W3) for Astroparticle Physics/Particle Physics

The position is preferably to be filled at the earliest opportunity.

The Deutsche Elektronen-Synchrotron DESY with its posts in Hamburg and Zeuthen (Brandenburg) is a world-leading research institution that manages the development, construction and operation of particle accelerators to study the fundamental structure and physical properties of matter. Research at DESY includes particle and astroparticle physics and studies of atoms, molecules and condensed matter using the latest generation of photon sources including free electron lasers in the X-ray band. DESY is member of the German research network Hermann von Helmholtz-Gemeinschaft Deutscher Forschungszentren. DESY wants to extend its research activities in Zeuthen in the fields astroparticle physics (including highenergy photons and neutrinos) and accelerator physics. To fill the above advertised position as head of DESY site Zeuthen DESY and the University of Potsdam are searching for an outstanding, internationally renowned scientist, preferably in the field astroparticle physics. Ideally, the candidate has several years of experience as leader of large research projects and science teams and has excellent knowledge of the international research environment in this field. As head of DESY site Zeuthen the candidate reports to the board of directors of DESY.

At the University of Potsdam and its physics and astronomy department there are research groups in the fields of stellar and extragalactic astrophysics and theoretical astroparticle physics. There is a lively interaction between the University and the Astrophysical Institute Potsdam (AIP), the Max-Planck-Institute for gravitational physics (Albert-Einstein-Institute, AEI), and DESY site Zeuthen. With this common call the cooperation between DESY site Zeuthen and the University of Potsdam shall be further strengthened. With the position as professor at the University of Potsdam the candidate has a teaching duty in the field astroparticle physics/particle physics of two lessons per week (2 SWS).

Prerequisites for the application are a doctoral degree and a record of research equivalent to the German "Habilitation". Scientific qualifications achieved in the private sector, outside Germany or as Junior professor will also be considered (§ 39 BbgHG).

Appointment will be made according to the laws of Brandenburg (Brandenburgisches Hochschulgesetz - BbgHG § 38). According to state law (§ 41 Abs. 1 BbgHG) the contract will be limited, in case it is the first appointment of the successful applicant as university professor, with the possibility of tenure after 2 years. Exceptions are possible, in particular if outstanding candidates from abroad or external to the university system cannot otherwise be acquired. In case of successful tenure review, there is no further appointment procedure.

Potsdam University and DESY are equal opportunity employers.

Please send applications until 3rd of September 2010 to Potsdam University, Office of the President, Am Neuen Palais 10, 14469 Potsdam, Germany.

facilities installed in Halls A, B, C, and D. The Deputy also serves as the Division Safety Officer and manages to oversee the Physics Division EH&S program.

The Deputy Associate Director provides support for the infrastructure necessary for assuring a user-friendly atmosphere, serves as a member of the Technical Advisory and Scheduling Committees, and advises the Associate Director on short-range experimental priorities. In particular, the Deputy has primary responsibility for overseeing/managing the details of the beam time schedule consistent with the broad directions defined by the Scheduling Committees.

The successful candidate will be an internationally recognized scientist in nuclear physics or a related field. The position requires a Ph.D. and significant relevant experience in Nuclear Physics or related field, and a demonstrated track record of resource and technical management or significant projects in design, construction, commissioning and/ or operation.

Hall A Group Leader

The Hall A Group Leader provides overall management of the physics research group for the hall. This includes leading the development of the research program through collaboration with users, staff, and advisory committee. The Hall leader oversees the staging and execution of the

scientific experiments. Additionally, the Hall Leader is responsible for the provision of appropriate experimental equipment for the balance of operations at 6 GeV and with special emphasis on the 12 GeV era, which will begin in 2013. The responsibilities also include management of all Hall scientific, post doc, engineering and technical staff, budgeting, planning and resource allocation.

The successful candidate will be an internationally recognized expert in the forefront of nuclear/ particle physics. A record of scientific excellence as demonstrated by extensive publication in nuclear/ particle physics is required. A Ph.D. in Experimental Nuclear or Particle Physics or the equivalent combination of education, experience, and specific training is required.

Interested candidates should submit a CV, publication list and letters of reference.

More information or to apply: <http://www.jlab-jobs.com/>

TJNAF is an Equal Opportunity/ Affirmative Action Employer.



Max-Planck-Institut für Physik

(Werner-Heisenberg-Institut)



The Max Planck Institute for Physics does fundamental research in particle and astroparticle physics from both an experimental and a theoretical perspective.

We invite applications for a

Postdoctoral position in the GeDet group

focussing on the development of germanium detectors for future large scale experiments. A possibility to participate in the GERDA experiment located at the Gran Sasso National Laboratory exists.

The main activity of the GeDet group is the detailed investigation of the characteristics of segmented n-type detectors. The development of new technologies for system integration is foreseen within studies evaluating the possibilities for future large scale germanium detectors.

The GERDA experiment is designed to search for the neutrinoless double beta-decay of ^{76}Ge . A participation in the analysis of first data is possible.

Formal requirements for this position are a PhD in experimental physics and experience with low background physics or semiconductor devices. The successful candidate will actively take part in the development and evaluation of germanium detectors. The evaluation includes detector modelling and the analysis of data obtained with existing detectors. He/she will take responsibility in adjusting and operating a test facility and play an important role in evaluating the prospects of future large scale experiments.

Salary and benefits are according to the German public service pay scale (TVöD Bund). The contract is initially limited to 2 years with the possibility of an extension. The Max Planck Society is an equal opportunity employer.

Further information can be obtained from Dr. I. Abt (E-Mail: isa@mppmu.mpg.de) or Dr. B. Majorovits (E-mail: bela@mpp.mpg.de). Interested applicants should address their application to:

Max Planck Institute for Physics
Ms. F. Happel
Föhringer Ring 6, D-80805 München
E-mail: happel@mpp.mpg.de



MAX-PLANCK-GESELLSCHAFT

It should include curriculum vitae, list of publications and a statement of research interests. The applicant should also arrange for three letters of recommendation to be sent directly to the MPI. The deadline is October 31, 2010 (applications arriving later will only be considered as long as the position is not yet filled).

Fresh jobs straight to your in-box

Sign up to the jobs
by e-mail alert from
brightrecruits.

brightrecruits.com



Postdoctoral Research Assistant: Grid Computing for Landslide Modelling

£29,853 - £33,600

This project will establish resource provisioning and data mining for landslide modelling for use in risk reduction. It will couple Grid software, developed for the LHC, with established software in the field of slope hydrology and geotechnics.

You will develop the current proof of principle system. The new system will allow use of large scale computing resources with secure storage and transparent access to data. You will have experience of the Python scripting language, as well as experience of Grid or Cloud computing. You will have good knowledge of metadata management and proven record of delivering sustainable software.

The project will be carried out as a partnership between Particle Physicists in the Department of Physics and academics within the School of Geographical Sciences. This is a full-time post offered on a fixed term contract for two years.

For informal enquiries please contact Professor N.H Brook on (0117) 954 6877 or e-mail: n.brook@bristol.ac.uk Further details and application form can be found at www.bristol.ac.uk/jobs Alternatively you can e-mail recruitment@bristol.ac.uk or telephone (0117) 954 6947, quoting reference number 15582.

The closing date for applications is 9.00am, Tuesday 24 August 2010.

EXCELLENCE THROUGH DIVERSITY



POSTDOCTORAL POSITION

High Energy Gamma-Ray Astronomy
and Particle Astrophysics

University of California, Los Angeles

The University of California Los Angeles (UCLA) invites applications for a Postdoctoral research position in high energy gamma-ray astronomy to strengthen the experimental astroparticle physics group. UCLA participates in forefront research in the areas of high-energy gamma-ray astronomy, ultra-high energy cosmic rays and neutrinos, and dark matter detection. The successful candidate will be expected to become involved in the design and prototyping of the future ground-based gamma-ray observatory CTA/AGIS and also to take part in the data analysis and ongoing operation of VERITAS.

The UCLA high energy gamma-ray astrophysics group has been actively involved in the world-wide effort to develop the next generation array of imaging atmospheric Cherenkov telescopes known as the Cherenkov Telescope Array (CTA) and formerly known in US as the Advanced Gamma Ray Imaging System (AGIS). The group's efforts are focused on the design and prototyping of the optical system for a novel Schwarzschild-Couder telescope as well as on simulation studies of the CTA performance. The group also participates in operation of Very Energetic Radiation Imaging Telescope Array System (VERITAS <http://www.astro.ucla.edu/~veritas/>) and conducts analysis and research utilizing data from VERITAS and Fermi Gamma-ray Space Telescope.

We encourage candidates with an experimental background in high energy particle physics, astrophysics, or an observational background in astronomy to apply for the position. A Ph.D., or equivalent degree, in physics or astronomy is required. Applicants should send a CV and arrange for three letters of recommendation to be sent to:

Prof. Vladimir Vassiliev
Department of Physics and Astronomy
University of California
Los Angeles, CA 90095-1547

The deadline for receipt of applications is November 1st, 2010. Screening of candidates will begin upon receipt of completed applications and will continue until the position is filled.

For inquiries please contact Prof. Vassiliev at vv@astro.ucla.edu.

The European XFEL will provide X-rays of unique quality for studies in physics, chemistry, life sciences, materials research and others. Located in Hamburg and Schleswig-Holstein, Germany, it will comprise scientific instruments for a wide range of experimental techniques. Construction of the European XFEL is underway, its commissioning is scheduled for 2014. The European XFEL GmbH is a multi-national non-profit company with DESY as the German shareholder. We are looking for a

Scientist for diagnostics of X-rays (f/m)

The position

- design and construct devices for the diagnostics of X-ray photon pulses, and verify their functionality by experiments with prototypes
- perform related research in collaborations at synchrotron and FEL facilities, such as photoionization spectrometry for online monitoring or photon-based long-undulator commissioning using an X-ray monochromator
- support simulation activities to determine the spatial and spectral distribution of the X-ray beam
- interface with scientists and engineers in related work packages like undulator systems and X-ray optics

Requirements

- PhD in physics or equivalent qualification and experience in the development and use of X-ray instrumentation
- ideally background in characterization of X-rays and ultrafast processes
- good communication skills and ability to work in an international team of physicists and engineers

For additional information please contact jan.gruenert@xfel.eu

Application: Please apply online via www.xfel.eu (**reference no. S-030**) and provide a motivating cover letter and a CV in English including a list of publications as well as at least two references.

Duration: This appointment is initially limited to 3 years.

Salary and benefits are similar to those of public service organizations in Germany. Handicapped persons will be given preference to other equally qualified applicants. The European XFEL GmbH is an equal opportunity and affirmative action employer and encourages applications from women. English is working language, knowledge of German is considered an asset.

The European XFEL GmbH intends to achieve a widely international staff. Non-German candidates hired from abroad receive an international allowance.

■ ■ ■ Deadline for application: 15 September 2010



Facility for Antiproton and Ion Research in Europe

The Facility for Antiproton and Ion Research (FAIR) is a new state-of-the-art accelerator facility, which will be built in international cooperation with various partner countries from Europe and overseas on the premises of the GSI Helmholtzzentrum für Schwerionenforschung GmbH near Darmstadt, Germany. FAIR builds on the experience and technological developments already made at the existing GSI facility and other institutes, and it incorporates new technological concepts and related applied research in the fields of structure of matter, especially of hadrons, nuclear, atomic and plasma physics. A system of storage and cooling rings for effective beam cooling and beam preparation at high and low energies and various experimental halls will be connected to the FAIR accelerator. The GSI accelerators – together with the planned proton-linac – will serve as injector for the new facility.

Construction of the new facility with a total investment of € 1 billion will be carried out under the leadership of a limited liability company (FAIR GmbH, in the course of formation) in close collaboration with GSI.

FAIR GmbH is an organisation formed on the basis of an intergovernmental convention of various partner states from Europe and overseas. Its role is to establish, provide, maintain and develop outstanding accelerator infrastructures and experimental facilities for scientific research and development with antiprotons and ions.

FAIR GmbH is now inviting qualified candidates to apply for the following key positions:

2 Subproject Leaders (m/f) - Building Construction and Civil Engineering Underground - Reference no. 9150-10.49

The Subproject Leaders report to the Head of Site & Buildings. They are responsible for the organisation and coordination of the respective subprojects to ensure a successful completion of the civil construction of the buildings for the FAIR facility.

2 In-Kind Coordination Assistants (m/f) Reference no. 9150-10.50

The In-Kind Coordination Assistants help the Group Leader In-Kind Coordination with tasks related to in-kind contributions, including the allocation of in-kind contributions to Shareholders and attributed values and the monitoring of the scheduled delivery dates and milestones.

Third Party Funding Officer (m/f) Reference no. 9150-10.51

The Third Party Funding Officer reports to the Administrative Director and gives advice to the Management on strategic involvement in projects funded by the EU and other third parties.

2 Accelerator Physicists / Technical Follow-up (m/f) Reference no. 9150-10.52

The holders of the positions report to the Group Leader Technical Follow-up in matters of the construction and technical realisation of the FAIR accelerators.

The official languages of FAIR GmbH are German and English. Therefore candidates must be able to work effectively in one of these languages and have a high level of knowledge of, and fluency in, the other.

Candidates may perform their work and duties on the basis of employment with FAIR GmbH, or secondment, assignment or provision of personnel to FAIR GmbH, as the case may be.

Competences and salary are adequate to importance and requirements of the position and conform to the GSI's salary scale equivalent to that for public employees. In addition to basic salary, FAIR GmbH offers attractive benefits and professional development in an international work environment.

Closing date is **2010-09-03**.

For further particulars and job description see www.gsi.de/informationen/internal/vw/pa/jobs.html and www.gsi.de/fair/jobs/index.html.

Qualified women are particularly encouraged to apply.

Handicapped persons will be preferentially considered when equally qualified.

Applications in English or German attaching curriculum vitae and covering letter quoting reference no. should be sent to

GSI Helmholtzzentrum für Schwerionenforschung GmbH
Abteilung Personal und Sozialwesen
Planckstraße 1 • 64291 Darmstadt
or online to: S.Maurer@gsi.de



BOOKSHELF

Extensive Air Showers: High-Energy Phenomena and Astrophysical Aspects – A Tutorial, Reference Manual and Data Book

by Peter K.F. Grieder, Springer. Hardback ISBN 9783540769415, £314 (€368.20, \$469).

Peter Grieder has compiled an exceptional collection of information and data on a major area of cosmic-ray physics: the air showers that are the observable results of energetic cosmic rays incident on the Earth's atmosphere. The subtitle correctly identifies this two-volume (1000 pages) book as a very complete and valuable resource for physicists working in this domain of cosmic-ray physics. It is also a most relevant and appropriate follow-on to Grieder's 2001 book, *Cosmic Rays at Earth*.

The flux of cosmic rays falls approximately as the cube of the energy (at energies above a few giga-electron-volts), so the flux above about 10^{14} eV is too low to study by direct (balloon or satellite) observation. Hence our knowledge of this astroparticle physics domain at higher energies is totally dependent on observations from the Earth, which in turn relate to the interactions of the primary cosmic rays in the Earth's atmosphere and the subsequent cascades – the air showers. For example, at energies above about 10^{19} eV, the flux of primary cosmic rays is only about one per square kilometre per year per steradian. The nuclear composition, energy spectrum, and astronomical sources of these unusually energetic particles are of great interest, but the means of studying them are totally dependent on understanding their interactions in the atmosphere and the resulting air showers.

These two volumes provide an excellent resource for understanding all of the relevant consequences and observables of these air showers: the hadron, muon, electron-photon, and even neutrino fluxes, their spatial and angular distributions, and their energy spectra. Grieder also discusses the various detection technologies: surface arrays of scintillation or water Cherenkov counters, muon counters, atmospheric fluorescence and air Cherenkov radiation detectors. Even novel technologies, such as the radio detection and study of air showers, are presented and discussed. The first volume, Part I, deals mainly with the basic theoretical framework of the processes that determine an air shower, while the second volume, Part II, consists primarily of a compilation of

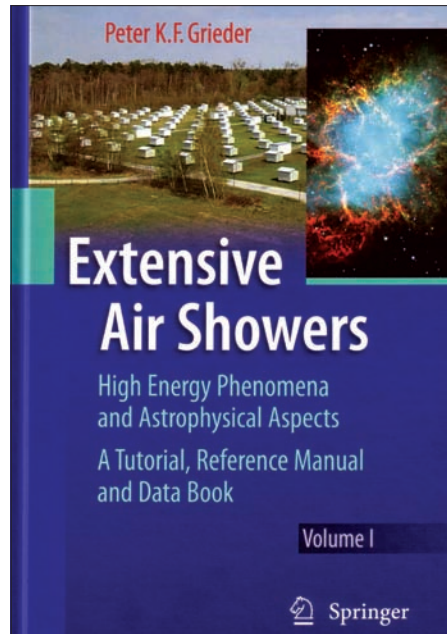

experimental data and related discussions, as well as predictions and discussions of individual air-shower constituents.

The collection of data and graphs from a great multitude of experimental observations is overwhelming, and most interesting. The strong-interaction physics that governs the behaviour of the interactions and the consequent reaction product numbers, energies, and angular distributions are also discussed, together with various Monte Carlo models that form the basis for the calculations of the observables. As the primary interactions of the higher-energy cosmic rays are at energies above those for which detailed inclusive distributions have been studied with particle accelerators, there remain uncertainties in the Monte Carlos and the consequent interpretation of these air-shower observables. Hence, while the energies of the primary cosmic rays can be reasonably well determined (from the total energy of the electromagnetic cascade plus observed muons and hadrons), some uncertainty in the atomic masses of the observed highest energy incident cosmic rays remains.

Although the most energetic cosmic rays are nuclei, astronomical gamma rays also initiate air showers, and it is relevant to discriminate between these and hadron-initiated showers. As with nuclear cosmic rays, direct satellite observation of the gamma radiation is being actively pursued. However at higher energies (above

Exact Solutions of Einstein's Field Equations

Second Edition

HANS STEPHANI
DIETRICH KRAMER
MALCOLM MACCALLUM
CORNELIUS HOENSELAERS
EDUARD HERLT

CAMBRIDGE MONOGRAPHS
ON MATHEMATICAL PHYSICS

about 1 TeV), surface installations that observe the gamma-initiated air showers, often with air Cherenkov detectors, are important. The characteristics of gamma-ray initiated showers and the relevant detector technologies are also discussed.

An extensive appendix in Part II identifies 65 air-shower observation installations, past and present, around the world, and notes their relevant properties such as altitude (many at elevations above 3000 m) and atmospheric depth, the energy thresholds of their muon detectors, and other characteristics. Sketches of the detector configurations of about half of them are also included. In addition, more than 30 underground (and underwater/under-ice) muon and neutrino detectors – past and present – are described.

This two-volume book certainly merits acquisition by groups working actively on air showers, the installations, data analysis, and physics interpretation. I am sure that it will prove to be an invaluable resource in this lively area of astroparticle physics.

Lawrence Jones, Michigan.

Exact solutions to Einstein Field Equations (2nd edition)

by Hans Stephani, Dietrich Kramer, Malcolm MacCallum, Cornelius Hoenselaers and Eduard Herlt, Cambridge University Press. Hardback ISBN 9780521461368, £107 (\$208). Paperback ISBN 9780521467025 £50 (\$94.99). E-book ISBN 9780511059179 \$140.

Soon after Einstein formulated his relativistic theory of gravitation – general relativity – two of the most celebrated solutions were found: the Schwarzschild solution, describing the gravitational field outside a spherically symmetric, static body, in 1915 about a month after the publication of Einstein’s work; and the Friedmann solutions in 1922 and 1924, which provide the basics of modern cosmology. Since then, in the nearly 100 years that have elapsed, thousands of solutions have been found.

Trying to enter, unguided, into the world of exact solutions is a formidable task. It is great news that this classic monograph has been re-edited in expanded form (the first edition dates from 1980). The authors have gone through the herculean job of looking at 4000 new papers since the first edition with a cut off at the end of 1999. Five new chapters have been added, and many of the previous ones have been substantially rewritten.

The book provides an excellent introduction to the mathematical structure of general relativity, and it is a useful companion to any regular course in the subject. The authors have concentrated on solutions to vacuum space-times, Einstein-Maxwell and perfect fluids. They describe in great detail the known solutions, possible equivalences, algebraic classifications, solution-generating methods etc. The exposition is always clear and elegant. It contains a thorough presentation of space-times with different groups of motion. We should be thankful to the authors for having undertaken this project. The second edition, like the first one, is a real masterpiece.

Luis Álvarez-Gaumé, CERN.

Murray Gell-Mann: Selected Papers by Harald Fritzsch (ed.), World Scientific. Hardback ISBN 9789812836847 £69 (\$105). Paperback ISBN 9789814261623 £32 (\$48). E-book ISBN 9789812836854 \$137.

As an admirer of Murray Gell-Mann (*CERN Courier* April 2010 p27), I can only applaud the initiative of Harald Fritzsch to publish a selection of Gell-Mann’s papers. What interested me most in the collection were not the papers published in journals, but rather, the contributions to conferences, talks and so on. In particular I can quote remarks Gell-Mann made at the 1956 Rochester conference, the famous comments

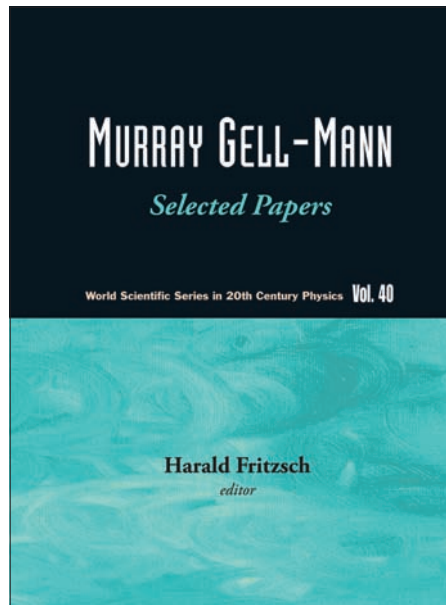

made in 1962 in Geneva where the Ω^- was predicted, the catalytic remarks of Bob Serber concerning the product of $3 \times 3 \times 3$ representations, and the discussions between Geoff Chew and Gell-Mann.

I was delighted to see a written version of the talk given by Gell-Mann at the celebration of Viki Weisskopf’s 80th birthday. (Immodestly, I can say that if this talk was given, it is thanks to me!) Gell-Mann also describes his state of despair after having been turned down by Princeton (Arthur Wightman has found out why), the decision to postpone committing suicide to after having seen how it would be at MIT, and his discovery of the wonderful atmosphere generated there by Weisskopf.

I was surprised that the 1960 paper by Gell-Mann and Maurice Lévy was not selected. It contains an important note added in proof where the introduction of an angle is proposed to explain both the weakness of strange particle decays and the discrepancy between the values of the Fermi constant obtained from muon decay and beta decay. This represents a first step in the direction of the well known Cabibbo angle.

I was not surprised not to find anything about “languages” because there is probably nothing written, but I can recommend the excellent talk that Gell-Mann gave at CERN in June 2004, which can be found at <http://indico.cern.ch/conferenceDisplay.py?confId=a042224>.

André Martin, CERN.

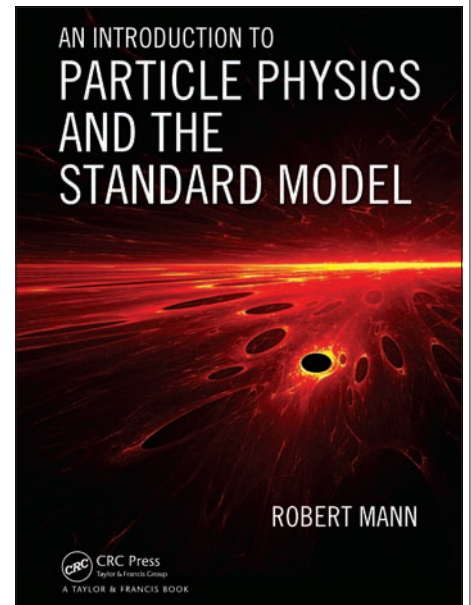

An Introduction to Particle Physics and the Standard Model by Robert Mann, CRC Press. Hardback ISBN 9781420082982, £49.99 (\$79.95).

Here is the 2010 vintage book on particle physics. It is addressed to senior physics undergraduates by Robert Mann, after 20 years of teaching experience at the University of Waterloo in Canada. The students are assumed to have a good working knowledge (at least a one-term course) of quantum mechanics, special relativity and electromagnetism. It consists of 25 chapters and 8 appendices, the latter covering subjects as diverse as natural units and “The Large Hadron Rap”. To complete the offering, a large selection of books at various levels are proposed for further reading. Among them the author found particularly helpful the books by Alessandro Bettini (2008), David Griffiths (2008) and Donald Perkins (2000) – and I fully agree.

Things exist (i.e. there is matter) and things happen (i.e. interactions occur). The goal of particle physics is to reduce to as elementary a level as possible our understanding of these two observations. An interesting question, then, is how does this materialize? The framework is settled in half a page. It works like a “lego” set. You are given a few bricks – electrons, protons, neutrons, neutrinos, other fermions and bosons, quarks and leptons, forces and symmetries – you are shown the Standard Model, and you play, that is you compute what you are possibly going to

compare with measurements.

First, the book prepares the theoretical tools, reviewing special relativity with particle kinematics; basics in group theory and classical mechanics; symmetries and conservation laws; particle classification according to angular momentum; and discrete symmetries (chapters 2 to 6).

The real game starts after a glimpse at the experimental tools: accelerators, from Van de Graaff to the Compact Linear Collider; and detectors, from scintillators to chambers of all kinds. The generic word “particle” rarely is specified (proton, electron and so on) which in this context seems difficult to accept although it is true that we have not yet learnt which particles we are talking about. We just let them decay and scatter and talk about decay rates, cross-sections and resonances, even building a toy theory to become acquainted with Feynman’s diagrams and rules. Eventually, after the Klein-Gordon and Dirac equations, gauge invariance is introduced in its simplest context in chapter 12, leading to the “photon” as “the particle whose wavefunction is A_μ (the four-vector potential)” and to some of the charged leptons (e , μ) in their role as sources of the electromagnetic field. For an experimentalist this is an over simplification – the photon has a rich history! – but it eases the transition to QED and its tests in chapters 13 and 14.

A slightly different cut, more phenomenological, is given to the later chapters. These account for the transition from nuclei to quarks, the quark model and its tests, the heavy quarks and QCD, before proceeding from beta decay to weak interactions (charged and neutral) to electroweak unification. The current problems related to the Higgs mechanism and to the testing of electroweak theory are dealt with in chapters 23 and 24, while the final chapter opens a window beyond the Standard Model.

All in all, the book is very much mathematics oriented, although such readers probably would prefer more rigorous, dedicated books. The beauty of mathematics

is often lost, diluted as it is in detailed calculations. Eventually these may help the student wishing to quantify the information obtained from experiment, but it is necessary to look elsewhere for a deeper insight into the art of knowing nuclear matter. For my taste, the book lacks the magic of discovery – the essence of the world of particle physics. Moreover, many illustrations are poor, even when simple diagrams are presented, and historically significant data plots are often omitted.

Maria Fidecaro, CERN.

Books received

Long-Range Interacting Systems: Lecture Notes of the Les Houches Summer School: Volume 90, August 2008 edited by Thierry Dauxois, Stefano Ruffo and Leticia F Cugliandolo, Oxford University Press. Hardback ISBN 9780199574629, £42.50 (\$79.95).

This book collects together the lecture courses and seminars on long-range interacting systems that were given at the Les Houches Summer School 2008. Leading scientists in mathematics and physics present their views on this fast growing and interdisciplinary field of research, by covering fundamental problems of probability, transport theory, equilibrium and non-equilibrium statistical mechanics, condensed matter physics, astrophysics and cosmology, physics of plasmas and hydrodynamics. The volume reviews state-of-the-art developments and provides an essential background to future studies.

The Stability of Matter in Quantum

Mechanics by Elliott H Lieb and Robert Seiringer, Cambridge University Press. Hardback ISBN 9780521191180, £35 (\$50). Online version ISBN 9780511654374, \$40.

Research into the stability of matter is a prime example of how modern mathematics can be applied to problems in physics. This account provides a complete, self-contained description of the subject. It introduces

the necessary quantum mechanics to mathematicians and aspects of functional analysis to physicists, before moving on to topics that include the electrodynamics of classical and quantized fields, Lieb-Thirring and other inequalities in spectral theory, stability of large Coulomb systems, gravitational stability of stars, basics of equilibrium statistical mechanics, and the existence of the thermodynamic limit.

On the Pulsar by B B Kadamsev and foreword by A Nomerotsky, World Scientific. Hardback ISBN 9789814289726, £18 (\$28). E-book ISBN 9789814289740 \$36.

This introduction to the physics of pulsars explains the subject in simple terms that are understandable to both physics undergraduates and the general public. *On the Pulsar* links together ideas about physics, informatics and biology, and contains many original examples, problems and solutions. It starts with simple examples about the regular structures that are possible in strong magnetic fields before the author suggests that special conditions on the pulsar can result in some forms of self-organization.

Lectures on Complex Networks: Oxford Master Series in Statistical Computational, and Theoretical Physics by Sergey N Dorogovtsev, Oxford University Press. Hardback ISBN 9780199548927, £39.95 (\$75). Paperback ISBN 9780199548934, £19.95 (\$35).

This concise modern introduction to the science of complex networks is based on lectures for university students and non-specialists. It aims to introduce the world of networks to readers without a serious background in mathematics or physics. The lectures fill the existing gap between popular science books and comprehensive reference volumes on complex networks, and provide the shortest path to the world of networks, discussing the main directions of modern research in this active field, as well as the history of network studies.

Heinzinger®
power supplies
supplies your world

HIGHPRECISION | HIGHCURRENT | HIGHVOLTAGE

We have the power!

highprecision
DC Power Supplies
& more



www.heinzinger.com

Postcard from Lindau

Simon Newman reminisces on four decades of the Lindau Nobel Laureate Meeting.

At the end of June I was in Lindau, the island town on Lake Constance, Germany, for the 60th annual meeting of Nobel laureates and young scientists. My first visit was in 1971 when, accredited as a journalist from CERN, I was to interview Werner Heisenberg. He had earlier declared a planned, more powerful European accelerator to be unnecessary on theoretical grounds, but had later advised the German government to back the project. When he explained his change of mind to a largely German audience in the small theatre used as a lecture hall he was loudly “booed” by those who feared that funds for their own research projects would vanish elsewhere in Europe. And so the Super Proton Synchrotron was built at CERN, where it now feeds an even bigger accelerator, the LHC.

The theatre stage was equipped with the traditional overhead projector and screen, a large blackboard and a plentiful supply of chalk. For many years simultaneous translation and German summaries of lectures were provided, but now English is the sole medium. Felix Bloch, CERN’s first director-general but long out of office – himself a Nobel laureate – came to the meeting, but CERN was still unfamiliar to many of the young scientists. Now the words CERN and LHC are frequently heard there.

Imposing, yet gentle, Count Lennart Bernadotte presided over the meetings that began in 1951. Two local medical doctors had foreseen the benefits that contacts with Nobel laureates would bring to German science and later it became an encounter between students, young researchers and the leaders of their profession. Count Lennart, a member of the Swedish royal family, had close links to Stockholm, and relations with Nobel bodies grew more and more fruitful. In 1982 he handed over the presidency to his wife, the late Countess Sonja, and now their daughter, Countess Bettina, has taken charge.

The 60th meeting was my 25th. Initially I attended only the physics meetings but later also those dedicated to chemistry and medicine, and I saw how over the years the



With the LHC live on the screen in Lindau, Nobel laureates debate about how CERN may shed light on dark aspects of the universe. Left to right: George Smoot, David Gross, John Mather, Carlo Rubbia, Martinus Veltman, and Gerardus 't Hooft. (Courtesy Christian Flemming/Lindau Nobel Laureate Meetings.)

new lecture hall held ever bigger international audiences. Laureates became more numerous and the press benches were well filled. Growing cross-fertilization between the natural sciences justified the introduction of interdisciplinary meetings in 2000. On that occasion the media were upset when only half of the 50 laureates turned up for the Sunday morning photo-call, the rest recovering from jet-lag having just arrived from the US – Nobel laureates are human after all!

At this year’s interdisciplinary event the hall almost burst at its seams with 650 young scientists from 68 countries, all eager to meet the 59 laureates present. Many thousands of applications from around the world had to be whittled down academically.

After retirement to the UK in the 1990s, I was asked to make the Nobel meetings known there so that UK students and researchers could join. This was done the old-fashioned way by snail-mail, telephone calls and personally persuading incredulous institutions that encounters between laureates and young scientists were real and valuable. As a result several groups of keen youngsters have gone to Lindau to be inspired by the leaders in their profession and by mingling with others their own age.

Modern technology – thanks to the invention of the web at CERN – now allows applicants to present their candidature direct to Lindau.

Alas, the Nobel prize is not contagious. Of the thousands of candidates so far allowed to attend once in their career, only one has made the leap from audience to lecture podium via Stockholm. One other, earlier turned down as a candidate, nevertheless came to Lindau in triumph as a laureate.

This year was the 10th anniversary of the creation of a foundation backed by states, institutions, industry and laureates, which provides a previously lacking firm basis for these meetings. With CERN now an academic partner, its current director-general, Rolf Heuer, attended this year’s celebrations. Former director-general and Nobel laureate, Carlo Rubbia, was active throughout the week, lecturing on underground physics, neutrinos and dark matter, and discussing energy and sustainability. He shared the platform with laureates David Gross, George Smoot, John Mather, Gerardus 't Hooft and Martinus Veltman in a debate about what CERN will teach us about the dark energy and dark matter of the universe. Arguments for and against were exchanged between debaters and audience members on Higgs, supersymmetry, string theory, new physics and extra dimensions. A live audiovisual link to the CERN Control Centre showed the steady operation of the LHC until a flash of lightening in Geneva stopped the machine in its tracks: nature may yield its secrets to the LHC, but not its ultimate power!

The medieval town of Lindau is now fully associated with the Nobel reunions, during which portraits of laureates greet you on approach to the island, and the Lennart Bernadotte House on Alfred Nobel Square is the home of the meeting secretariat. The intimacy of earlier years may have gone, but if, in 2050, the centenary should welcome a hundred laureates and more than a thousand young scientists to the island, I wish I could be there.

Simon Newman, CERN (1968–1985).

Single Photon Counting
No Noise
High Dynamic Range
Fast Frame Rate
Adjustable Energy Threshold

DECTRIS X-ray detector systems

DECTRIS offers a wide variety of detector systems for a broad range of applications

PILATUS 2-D detector systems

PILATUS detector systems are based on CMOS hybrid-pixel technology and deliver outstanding results in various applications. A wide range of models ensures that a suitable PILATUS detector can be chosen for every measurement.



MYTHEN 1-D detector systems

MYTHEN is a one dimensional silicon strip detector system, which can be combined to form multi-detector arrays covering large angles (MYTHEN 6K).



XBPM Beam Position Monitors

XBPM4 is a 4-quadrant x-ray beam position monitor based on CVD diamond technology, suitable for hard x-ray synchrotron beam lines.



CAEN Silicon PhotoMultiplier Development Kit

The all-in-one solution for Single Photon Counting and Spectroscopy Applications

CAEN realized a modular development kit dedicated to Silicon Photomultipliers, representing the state-of-the-art in low light field detection with photon number resolving capabilities.



Desktop Digitizer (DT5720A)

- 2 Channel 12bit 250 MS/s Digitizer
- Digital Pulse Processing for Charge Integration
- Best suited for PMT and SiPM/MPPC readout at low and high rates
- Mid-High speed signals (Typ: output of PMT/SiPM)
- Good timing resolution with fast signals (rise time < 100 ns)
- Optical Link and USB 2.0 interfaces



2 Channels General Purpose Amplifier and Power Supply (SP5600)

- Variable amplification gain (up to 50 dB)
- Low noise, not to spoil the sensor performance for small signals
- Wideband, to comply with the fast sensor response
- Fast leading edge discriminator
- Provides the bias for the sensor with temperature stabilization (resolution of 0.1 °C)
- USB 2.0 interface



Led Driver (SP5601)

- Width of pulse $3 \div 60$ ns
- LED colors: yellow (590nm) or blue (430nm)
- Pulse generator: internal/external
- Optical output connectors: FC

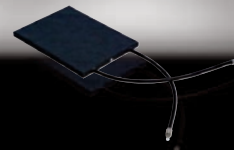

Scintillating Tile (SP5602)

- Sensitive volume: $100 \times 100 \times 10$ mm³
- Scintillator: polystyrene
- Light guide: embedded WLS fiber
- Output connectors: FC



Mini Spectrometer (SP5603)

- Mechanical structure for optimal SiPM to crystal coupling
- Crystal dimensions: $3 \times 3 \times 15$ mm³
- Available crystals: LYSO, BGO, CSI



Set-up for SiPM testing & characterization

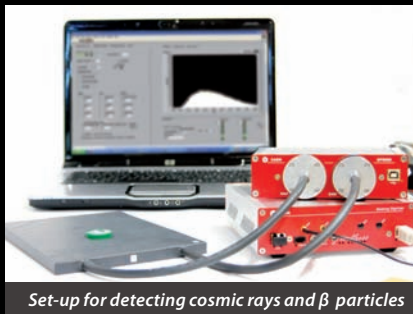

Set-up for detecting cosmic rays and β particles

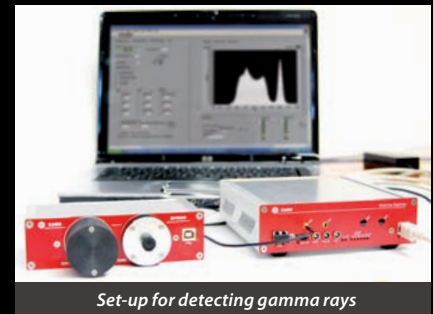

Set-up for detecting gamma rays

The different building blocks can be assembled in a customized configuration, according to the specific application and the user's requirements. Upon request, sensors from the main producers can be provided, fully integrated in the front-end.

The kit was developed within the EC-FP6 project RAPSODI, licensed to CAEN by the Research & Technology Development parties.

www.caen.it

Small details Great differences

Meet us at the following events:

HFI/NQI 2010 - 3rd Joint International Conference on Hyperfine Interactions and International Symposium on Nuclear Quadrupole Interactions

September 13 - 17, 2010

TWEPP 2010 - Topical Workshop on Electronics for Particle Physics

September 20 - 24, 2010

XCVI Congresso Nazionale Società Italiana di Fisica

September 20 - 24, 2010

SPIN2010 - 19th International Spin Physics Symposium

September 27 - October 2, 2010